

installation and user manual

HYBRID SOLAR PV INVERTER

RS 3.6 - 6.0 HYBRID



INTRODUCTION

Thank you so much for choosing RS 3.6 – 6.0 HYBRID, the latest generation of hybrid PV string inverters (hereinafter referred to as “inverter”) designed and developed by Riello Solartech.

Our company is specialised in the development and production of photovoltaic inverters. The solar inverters in this series are high-quality products, carefully designed and constructed with the aim of ensuring high performance.

This user manual introduces the inverter in terms of its installation, electrical connections, operation, commissioning, maintenance and troubleshooting.

For information regarding use and to obtain maximum performance from your equipment, this manual should be CONSULTED BEFORE OPERATION.

NOTE: some images contained in this document are for information purposes only and may not faithfully reproduce the parts of the product represented.

Application Model

Hybrid PV Inverter

- **RS 3.6 HYBRID** PV single phase inverter with two MPPT inputs and battery integration, 3.6kW nominal power
- **RS 6.0 HYBRID** PV single phase inverter with two MPPT inputs and battery integration, 6.0kW nominal power

Lithium Battery

- **RS BATLIO 5120** Stackable battery modules, 5.12kWh

Intended Recipients





This user manual is intended for photovoltaic (PV) inverter operating personnel and qualified electrical technicians.

Note:

this user manual is subject to change without prior notice. The latest version of the user manual and additional information on the product are available on <http://www.riello-solartech.com>, and/or by consulting your dealer.

Symbol Conventions

The safety symbols used in this manual, which highlight potential safety risks and important safety information, are listed below:

Symbol	Description
 DANGER	Indicates an imminently hazardous situation which, if not correctly followed, will result in serious injury or death.
 WARNING	Indicates a potentially hazardous situation which, if not correctly followed, could result in serious injury or death.
 CAUTION	Indicates a potentially hazardous situation which, if not correctly followed, could result in moderate or minor injury.
 NOTICE	Indicates a potentially hazardous situation which, if not correctly followed, could result in equipment failure or property damage.
 NOTE	Calls attention to important information, best practices and tips: supplements the safety instructions to optimise your use of the PV inverter and reduce wastage of resources.

SAFETY PRECAUTIONS

Personnel Safety

- The PV inverter must be installed, electrically connected, operated and maintained by a specially trained technician.
- The qualified technician must be familiar with the safety regulations concerning the electrical system, the working process of the PV power generation system and the standards of the local power grid.
- The technician must read through this User Manual carefully and master it before any operation.
- Ensure children are kept away from the inverter.

PV Inverter Protection

 NOTICE	Upon receiving the PV inverter and/or the batteries, please check whether it was damaged during transport. If it was, please contact your dealer immediately.
--	---

- Do not tamper with any warning signs on the inverter's enclosure, because these signs contain important information on safe operation.
- Do not remove or damage the nameplate on the inverter's enclosure, because it contains important product information.
- When not in use, the inverter must be disconnected and stored in a cool, dry and well-ventilated place.

Battery Protection

 NOTICE	Upon receiving the battery, please check whether it was damaged during transport. If it was, please contact your dealer immediately.
--	--

- The battery module must be protected against short circuits during transportation and installation.
- Do not disassemble/break the Battery. The electrolytes present can be toxic and cause serious harm to people. Damage caused by improper installation/operation is NOT covered under the product warranty
- All batteries connected in parallel must be of the same model and have the same firmware version (also important in a possible replacement of the batteries or modification of the storage system in the future).
- When not in use, the battery modules must be disconnected and stored in a cool, dry and well-ventilated place (for more information, see the Storage chapter).

Installation Safety

 NOTICE	Please read the User Manual carefully before installing the PV inverter; warranty or liability will be voided if damage is caused by installation faults.
--	---

- Ensure that there are no electrical connections around the PV inverter ports prior to installation.
- The Inverter and Battery modules must be installed in well-ventilated places. Do not install in airtight or poorly ventilated cabinets or places. This could be extremely dangerous for the performance and life of the system (for more information, see the Installation chapter)
- To reduce the risk of fire, do not cover or block the cooling vents. Keep the system out of direct sunlight. DO NOT approach explosive or flammable materials. DO NOT approach ovens, flames or other heat sources in order to avoid possible fires or explosions.
- The DC switch and Battery switch are used as disconnect devices, therefore they must be easily accessible.
- To prevent fire and electric shock, ensure that existing wiring is in good condition, of good quality, and that wires are not undersized.
- Use only accessories recommended by the manufacturer. Unsuitable / unrecommended accessories can cause fire, electric shock or personal injury.

Electrical Connections

 DANGER	Before installing the inverter, check all electrical ports to ensure that there are no damages or short-circuits. Otherwise, personal injury and/or fire will occur.
--	--

- Only connect PV strings to the PV input connectors of the inverter; do not connect any other DC power sources to the input connectors.
- Before connecting PV modules, ensure that their voltage is within the safe range; when exposed to any sunlight, PV modules can generate high voltage.
- Ensure that the output voltage of the proposed PV array is lower than the maximum rated input voltage of the inverter; otherwise, the inverter may be damaged and the warranty cancelled.
- Static electricity may damage electronic components. Appropriate method must be adopted to prevent such damage to the inverter.
- All electrical connections must meet the electrical standards of the relevant country or region.
- Cables used for electrical connections must be properly secured, well-insulated and made to the appropriate specification.

Operation and Commissioning

 DANGER	While the inverter operates, high voltage can lead to an electrical shock hazard and even cause personal injury. Therefore, operate the PV inverter strictly according to the safety precautions in this User Manual.
--	---

- Unless permission has been obtained from the power company of the country/region, the grid-tied PV inverter cannot start generating power.
- Follow the procedures for commissioning described in the User Manual when commissioning the PV inverter.
- When the PV inverter is operating, do not touch the surface of any other parts except for the DC switch; its constituent parts will be extremely hot and can cause burns.

- Do not unplug AC and/or DC terminals when the inverter is running.

Maintenance

 DANGER	Power OFF all electrical terminals before performing inverter maintenance; strictly comply with the safety precautions stated in this document when operating the inverter.
--	---

- Do not disassemble the equipment. Contains no user-serviceable parts. Attempting to repair the equipment yourself can result in electric shock or fire and will void the manufacturer's warranty
- For personal safety, maintenance personnel must wear appropriate personal protective equipment (such as insulation gloves and protective shoes) for inverter maintenance operations.
- Place temporary warning signs or erect fences to prevent unauthorised access to the maintenance site.
- To avoid electric shock, wait at least 5 minutes after powering off the inverter prior to any operation.
- Strictly follow the maintenance procedures specified in the User Manual.
- Check the relevant safety and performance of the inverter; rectify any faults which may compromise the safe operation of the inverter before restarting it.

Battery Maintenance

 DANGER	Battery maintenance must only be performed by qualified and competent technical personnel. The manufacturer is not liable for damage to people or things caused by failure to comply with the instructions.
--	---

IMPORTANT: Replace the batteries with batteries or battery packs of the same type.

Some IMPORTANT rules to be CAREFULLY followed when carrying out battery maintenance:

- Remove watches, rings or other metal objects.
- Use tools with insulated handles.
- Wear rubber gloves and shoes.
- Do not place tools or metal parts on top of the batteries.
- Disconnect all energy sources before connecting and/or disconnecting the Battery terminals.
- Both positive and negative poles must be isolated from earth.

Additional Information



 NOTICE	To avoid any other unforeseeable risk, contact Riello immediately if any safety issue emerges during operation.
--	---

 DANGER	RISK OF VOLTAGE FEEDBACK Before operating on this circuit -Disconnect the accumulation system (ESS) -Then check for the presence of Dangerous Voltage between all terminals, including the protective earth.
--	---

PROTECTING THE ENVIRONMENT

This product does not contain hazardous materials such as CFCs, HCFCs or asbestos.

Product packaging is made from RECYCLABLE MATERIALS. The disposal of individual components must be performed in accordance with current legislation in the country where the product is used. Refer to the following table for material identification:

<i>DESCRIPTION</i>	<i>MATERIAL</i>	
Packaging box	Corrugated cardboard (PAP)	
Protective bag	High-density polyethylene (HDPE)	
Foam	Low-density polyethylene (LDPE)	



To comply with the European Directive 2002/96/EC relating to electrical and electronic waste and its implementation as a national law, electrical equipment that has reached the end of its useful life and flat batteries must be separated from general waste and handed over to the appropriate authorized collection and recycling centres.

Any device that is no longer needed must therefore be returned to the distributor or disposed of at an authorized collection and recycling center in your area. Ignoring this European Directive can have potentially negative effects on the environment and your health!

LIMITED GUARANTEE

The equipment you have purchased has been constructed according to the most modern techniques and was rigorously tested before leaving the factory.

During the guarantee period, the manufacturer shall repair or replace parts that prove defective, provided that such defects have not been caused by incompetence or negligence of the buyer, fortuitous events or force majeure (lightning, fire, flood, etc.), incorrect or inadequate installation other than as stated in the manual, unsuitable transport or delivery, opening of the unit by unqualified personnel or breaking of the closure seal, modification, testing or unauthorised repair, use or application beyond the limits defined by the manual, or application beyond those defined by safety standards (VDE, UL, etc.).

It is the responsibility of the person applying for technical assistance from Customer Service to provide detailed information about the detected failure or malfunction.

The repair and/or replacement of parts or the device shall be implemented at the discretion of the supplier.

Any repair under guarantee will be performed by the manufacturer or an authorised service centre. Equipment must arrive at the risk and expense of the customer in its original packaging so as not to cause further damage.

If repairs must be performed directly at the customer's premises, the customer shall be charged for expenses and hours of travel, while the costs for labour and parts shall be borne by the manufacturer. This guarantee does not in any case cover the replacement of equipment or compensation for any direct or indirect costs or claims for damage caused by device malfunction.

© No part of this manual may be reproduced without prior permission from the manufacturer.

For the purpose of improvement, the manufacturer reserves the right to change the product described at any time and without notice.

CONTENTS

PRESENTATION	- 6 -
Product presentation	- 6 -
INSTALLATION	- 9 -
Preliminary checks	- 9 -
Electrical installation	- 19 -
USE	- 31 -
System operation	- 31 -
User interface	- 33 -
Working mode	- 36 -
Using the app	- 42 -
Maintenance	- 52 -
Troubleshooting	- 53 -
Storage	- 57 -
Disposing of the product	- 58 -
APPENDIX	- 59 -
Technical specifications	- 59 -
Inverter	- 59 -
Battery	- 61 -
System	- 61 -

PRESENTATION

PRODUCT PRESENTATION

Our hybrid storage system (ESS - Energy Storage System) is designed to supply energy continuously to the loads connected to it using, depending on the different power supply situations, photovoltaic energy, mains power and/or the energy stored in the dedicated battery modules. In the absence of sunlight, high energy demand or blackouts, you can use the energy stored in this system to meet your energy needs at no additional cost. Furthermore, this energy storage system helps you pursue the goal of energy self-consumption and energy independence.

Below is a simple graphical representation of a typical energy storage system:

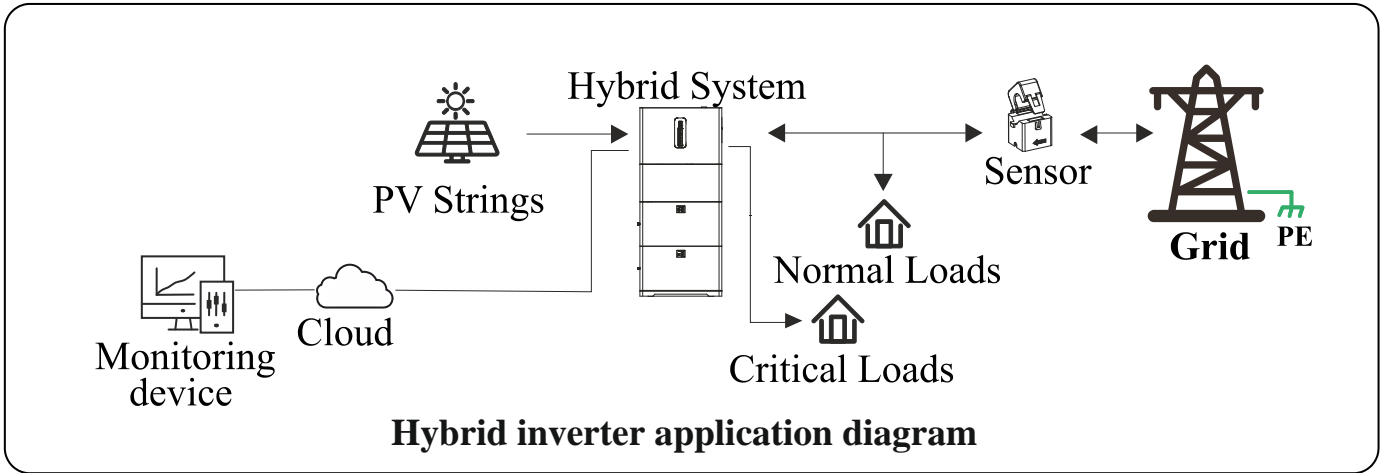

WARNING	The inverter is transformerless. Add an isolation transformer before grounding the positive/negative terminal of the PV modules (such as a thin-film module) for operation.
WARNING	Do not connect PV modules in parallel to several PV inverters for operation.

Model Description

The number in the model's name indicates the power class of the inverter, for example:

RS 6.0 HYBRID
Power class 6kW

Battery configuration and capacity

One or more batteries RS BATLIO 5120 can be stacked to expand the capacity. Each battery pack has its own integrated power control module, the system supports a maximum of six battery packs in parallel, with the following capacity.

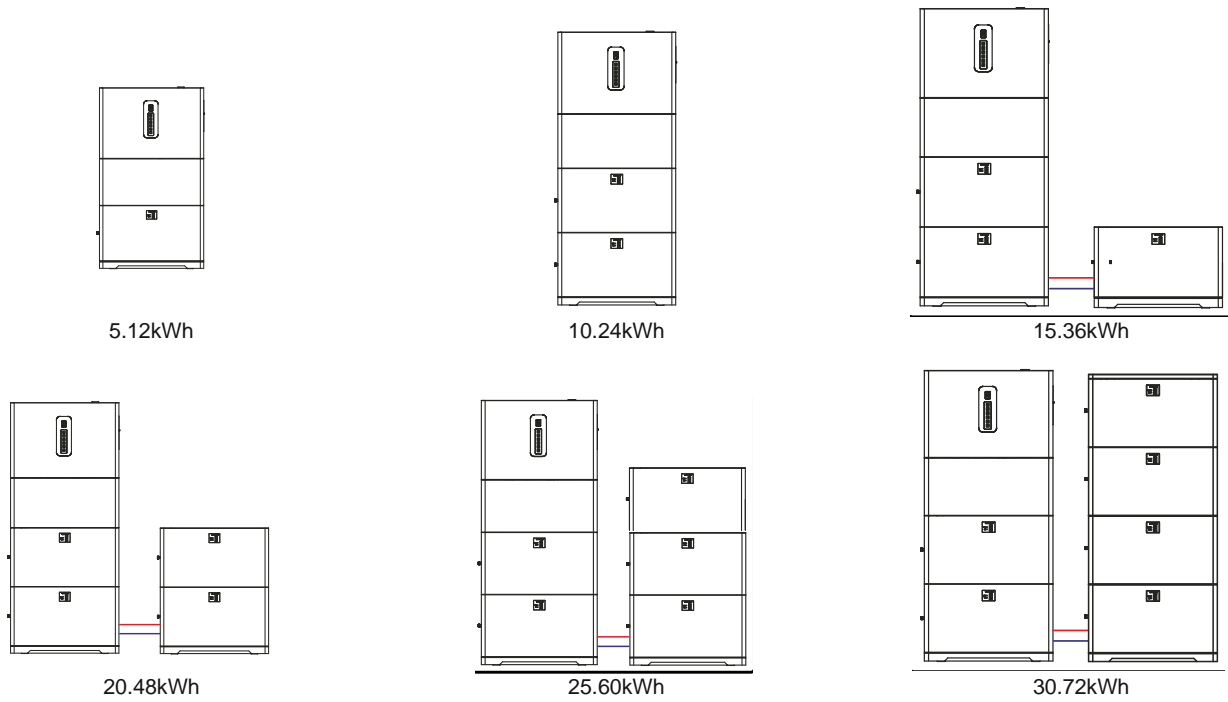

Hybrid System Appearance

The following image, for example purposes only, shows a typical hybrid system with 2 batteries and an inverter.

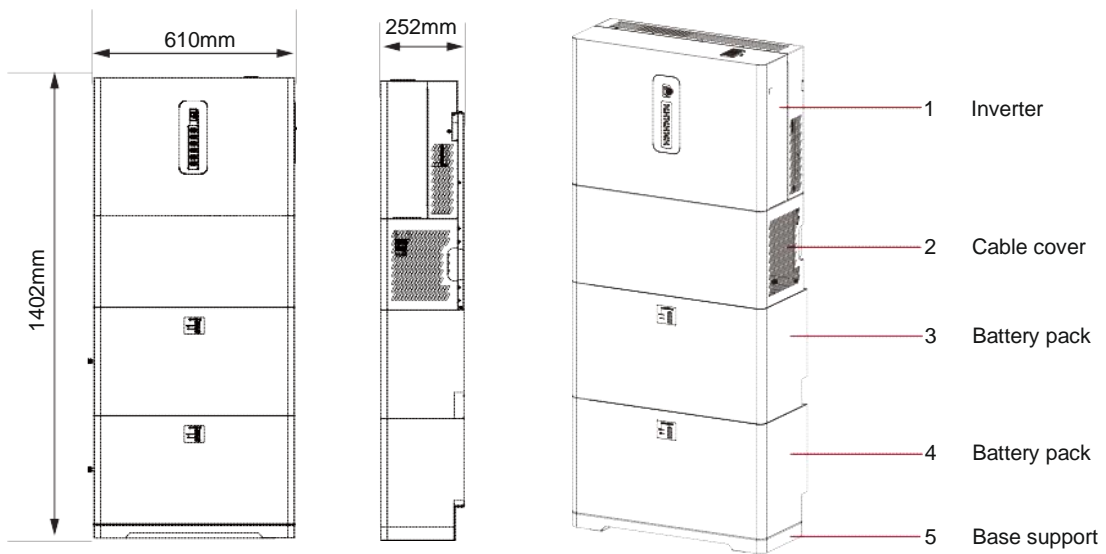

Connections area of Inverter

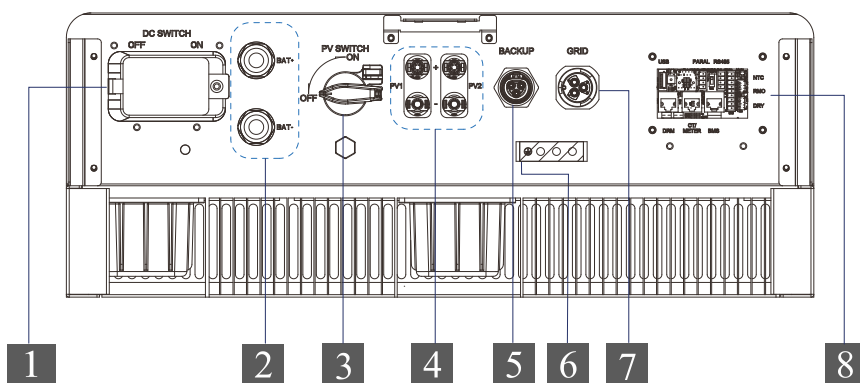

1. DC Switch
2. Battery connections
3. PV Switch
4. PV connectors
5. Backup output connector
6. Ground connection
7. Grid input connector
8. Communication ports
9. Slot for Wi-Fi/Ethernet module connection

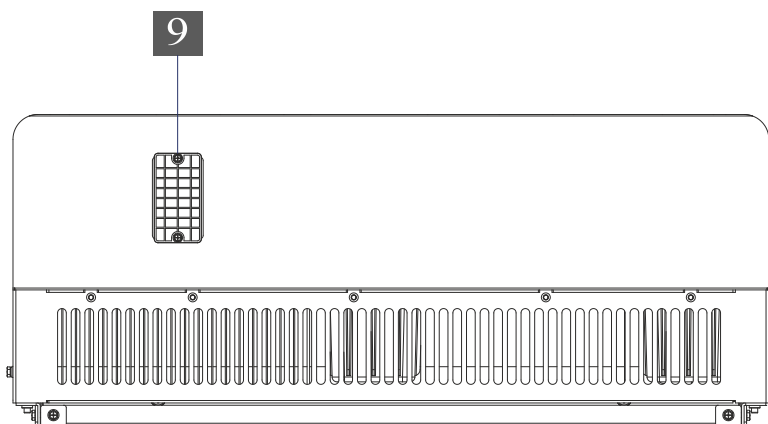

Connections area of Battery Pack

Fronts view

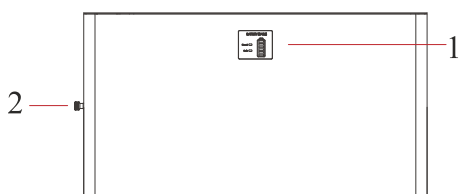

Left view

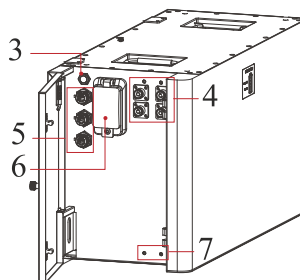

1. Battery indicators
2. Battery connections side screw
3. ON/OFF Button
4. Battery connectors
5. Communication ports
6. DC Breaker
7. Grounding connection

Connections Area of Base support

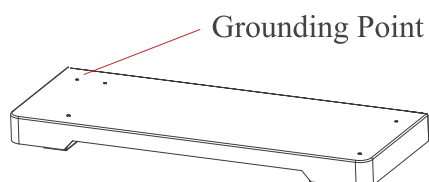

INSTALLATION

PRELIMINARY CHECKS

Checking the packaging contents

- Upon receiving the inverter and/or batteries, check that the packaging materials are intact.
- After unpacking, check that the deliverables are complete, intact and consistent with your order list.
- Examine the PV inverter, batteries and their fittings for any damage such as scraps and cracks.



NOTICE

If any of the damage mentioned above is found, contact the dealer immediately.

Packing Assy of inverter

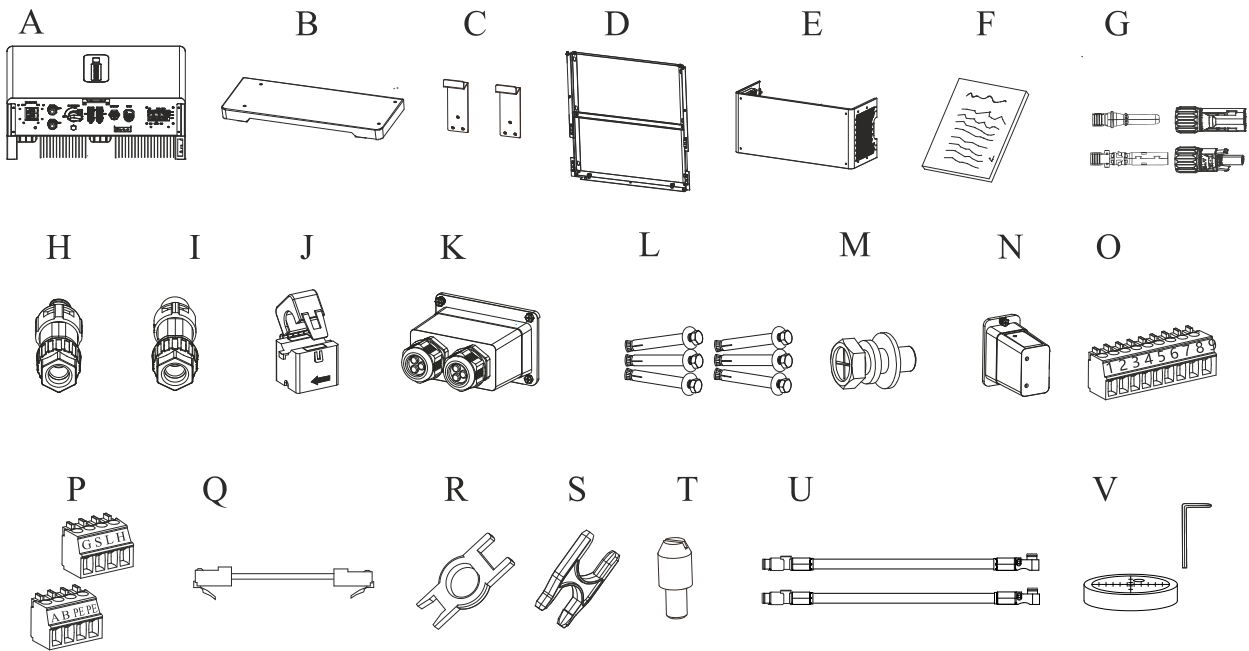

A	Inverter	B	Base support
C	Brackets for base support (2x)	D	Wall bracket for inverter
E	Cable cover	F	File package
G	PV terminal connector group (PV+/PV-)	H	Grid connector
I	Backup connector	J	Current measuring transformer
K	Communication cables' cover	L	M6 Expansion screws (8x)
M	M4 Security screws (8x)	N	Wi-Fi Module
O	9-pin Terminal	P	4-pin Terminals (2x)
Q	BMS Communication cable	R	Removal tool for PV connectors
S	Removal tool for Grid/Backup connectors	T	Locating pins (4x)
U	Power cables for batteries (some inverters have them incorporated)	V	Base feet regulation tools (bubble level and Allen key, only for some versions)

Packing Assy of battery

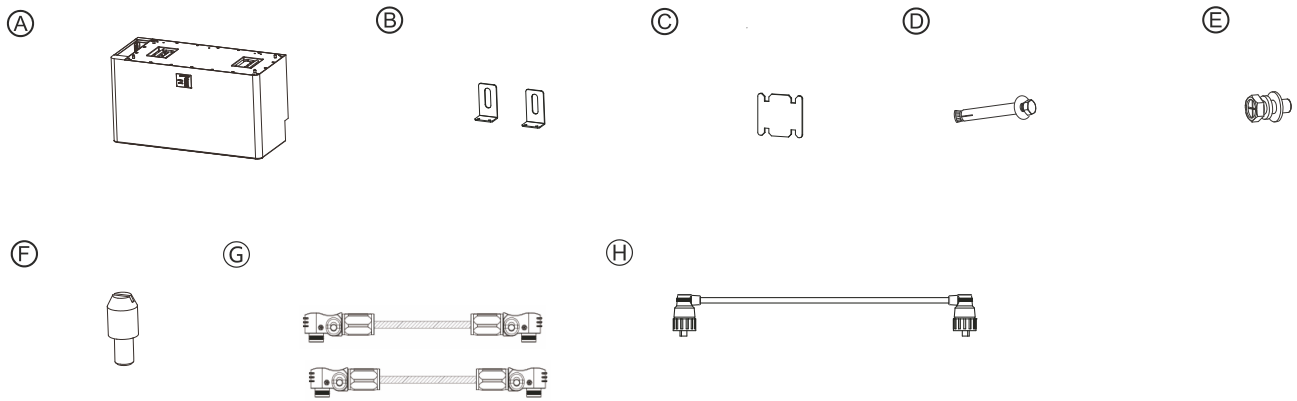

A	Battery	B	Mounting brackets (2x)
C	Connection strap for grounding	D	M6 Expansion screws (2x)
E	M4 Security screws (6x)	F	Locating pins (4x)
G	Battery cables (BAT+/BAT-)	H	Link communication cable (BAT to BAT)

Packing Assy of RS Hybrid Side Mounting Kit (XES2RS01A, optional)

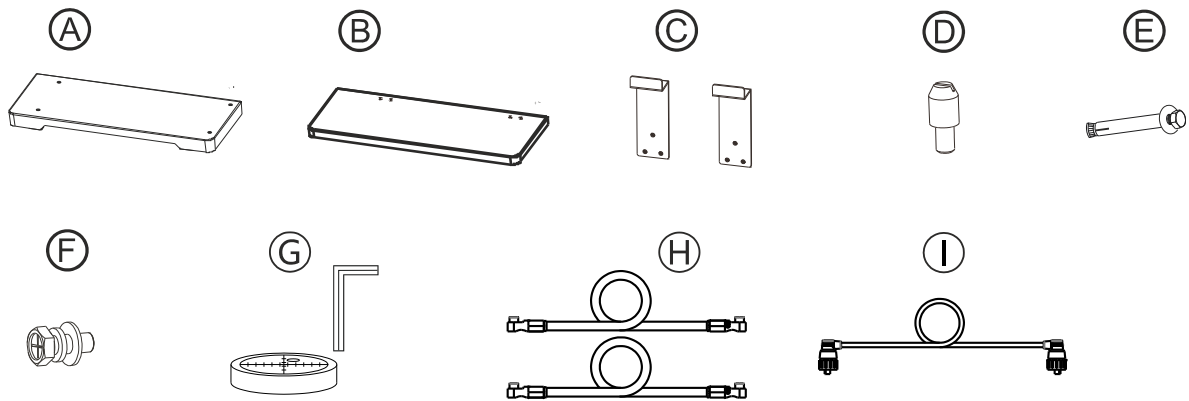

A	Base support	B	Top cover
C	Brackets for base support (2x)	D	Locating pins (4x)
E	M6 Expansion screws (2x)	F	Security screws M4 (6x) and M5 (4x)
G	Base feet regulation tools (bubble level and allen key, only for some versions)	H	Battery cables (BAT+/BAT-)
I	Communication cable (LINK COM)		

Packing Assy of RS Hybrid Wall Mounting Kit (XES2RS02A, optional)

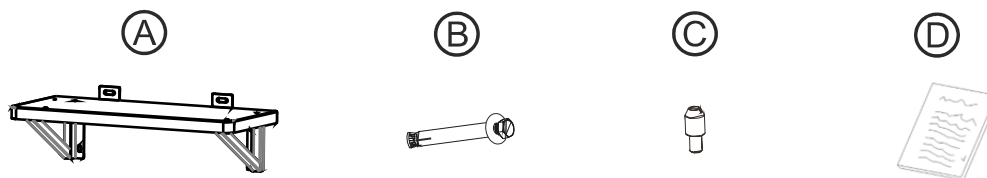



A	Wall mounting bracket	B	M6 Expansion screws (6x)
C	Locating pins (4x)	D	Installation guide

Moving the inverter

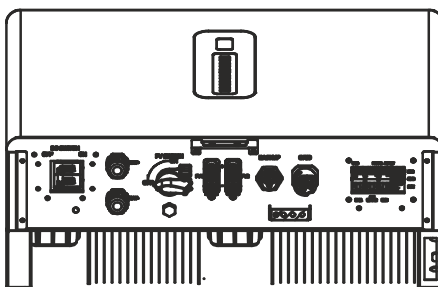
After checking the outer packaging, move the PV inverter to the designated installation position horizontally, as shown in the figure below.









 CAUTION	<p>The inverter is relatively heavy! To prevent device damage and personal injury, arrange two people or a lifting mechanism to move the inverter and handle with care.</p>
 CAUTION	<p>Do not place the PV inverter with its wiring terminals in contact with the floor, because the power ports and signal ports at the bottom of the device are not designed to bear the weight of the inverter. When placing the inverter on the floor horizontally, place foam or paper under it to protect its enclosure.</p>

Identifying the PV Inverter

Nameplate

After removing the PV inverter from its packaging box, identify it by reading its nameplate affixed to the side of the inverter. The nameplate contains important product information: model, communication/technical specifications, and compliance symbols.

	<p>Risk of electric shock The device contains high voltages, both alternating and direct current, and high leakage currents may be generated during operation. To avoid the risk of electric shock during maintenance or installation, make sure that all DC and AC connection terminals are disconnected. First connect the grounding wire to ground and disconnect it last during maintenance. Check for the proper phases and neutral connection. If the unit is used without following the specifications of the manufacturer, the protection provided by the equipment may be impaired. Disconnect the inverter from the grid, the batteries and from the photovoltaic generator before cleaning the photovoltaic modules: an unexpected capacitive current from the surface of the modules may surprise operators, causing them to fall off the roof.</p>
	<p>Handling the photovoltaic inverter The photovoltaic inverter must only be handled by qualified service personnel. When the photovoltaic generator is exposed to sufficiently intense light, it generates DC voltage, and when connected to the device, it charges the bulk capacitor. This also applies to batteries if present. After having disconnected the photovoltaic inverter from the grid, batteries and the photovoltaic generator, an electric charge may remain in the bulk capacitor. Please wait at least 5 minutes after disconnecting the device from the energy sources before handling it.</p>
	<p>Refer to the user manual To avoid damage and/or injuries, always refer to the user manual before operating the inverter. This also ensures high levels of security and high efficiency of the inverter. If any prescriptions are ignored, this can result in injuries and/or equipment damage, not covered by the warranty.</p>
	<p>Hot surfaces Although it has been designed in accordance with international safety standards, the photovoltaic inverter may become hot during operation.</p>
	<p>CE The product complies with the European CE Certification</p>
	<p>Product disposal The PV inverter contains hazardous materials for the environment. Do not dispose the inverter as household waste, always refer to local standards for the disposal of the inverter.</p>

Installation Requirements

Basic Requirements

- The inverter and batteries are IP66 compliant and can be installed both indoors and outdoors.
- The installation site must be inaccessible to unauthorized personnel due to the high heat sink temperature.
- Do not install the PV inverter in areas containing highly flammable materials or gases.
- The carrier where the inverter is mounted must be fire-proof. Do not mount the inverter on flammable building materials.
- To ensure optimum operation and long operation life, the ambient temperature must be below 50° C.
- The PV inverter must be mounted in a well-ventilated environment to ensure good heat dissipation.
- To ensure long operation life, the storage of the inverter must not be exposed to direct sunlight, rain, or snow. It is recommended that the inverter be mounted in a sheltered place.
- Do not install the inverter in a rest area since it will cause noise during operation.
- The installation height should be reasonable and suitable to easily operate and view the display.
- Product label and warning symbols shall be clear to read after installation.

Installation Environment Requirements



NOTICE

An improper installation of the system may cause malfunctioning or performance loss.

- It is recommended that the inverter be installed at eye level to facilitate operation and maintenance.
- Reserve enough clearance around the inverter to ensure sufficient space for installation and heat dissipation, as shown in the picture below.

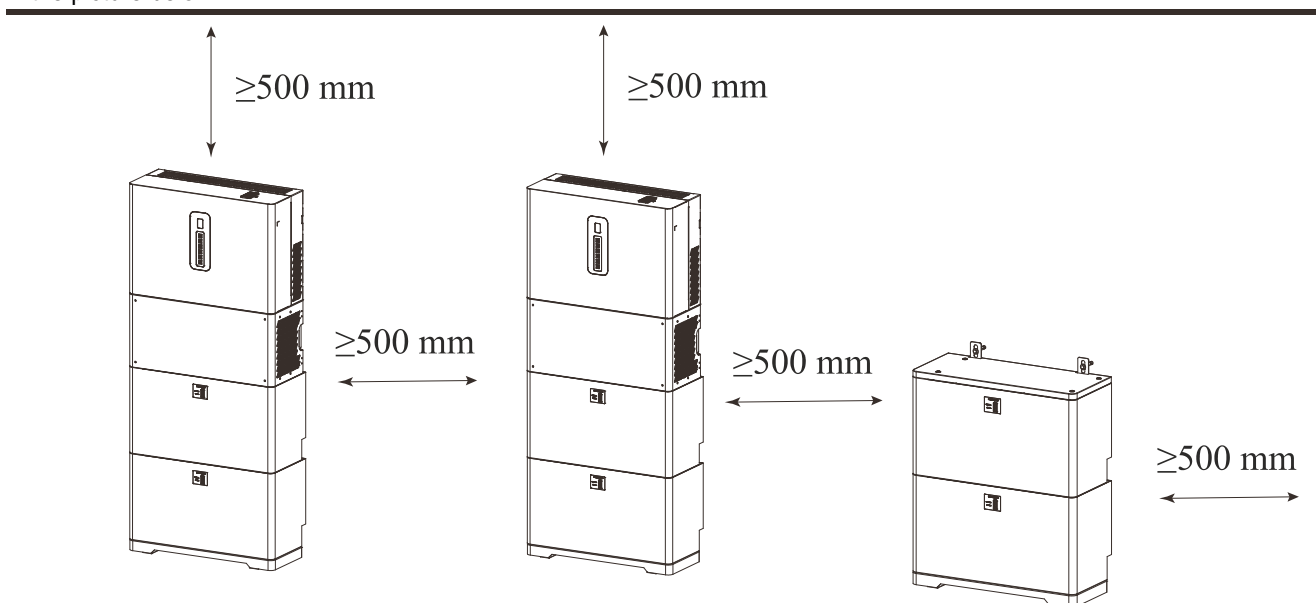

Installation

Base support installation

Step 1 Fix the two brackets for the support base on the rear side of the base with 6x M4 security screws supplied (tighten with a torque of 1.2Nm). Install the 4 alignment pins provided on the top side of the base.

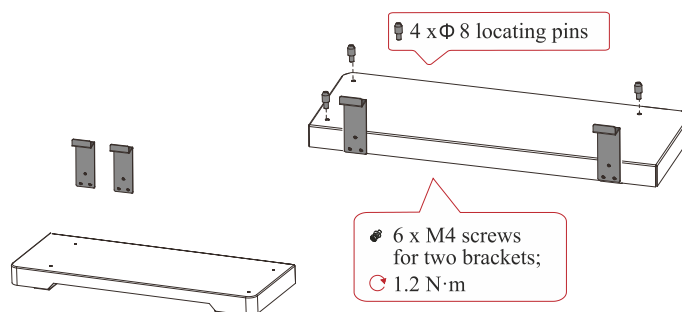

Step 2 Place the base against the wall. The skirtboard must have a maximum width of 15mm and a maximum height of 100mm.

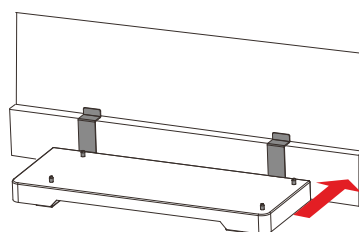

Step 3 Set the adjustable feet's height using the included bubble level and allen key.

 NOTE	Some versions of the base support do not include adjustable feet. In those cases, ignore this step.
--	---

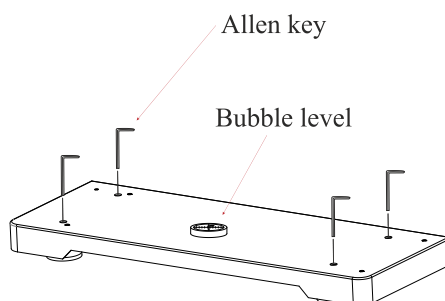

Step 4 Secure the base support with 2 expansion screws. Refer to step 4 to 6 of the next section for more details.

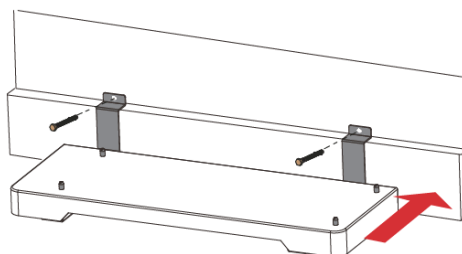

System installation (typical configuration with 2 batteries and inverter)

Step 1 Align the first battery pack with the base support according to the locating pins. After alignment, press down the battery tightly to make sure it fits into place.

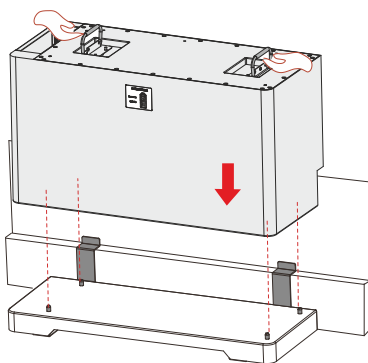

Step 2 Install four locating pins (supplied with the battery module) on top of the battery.

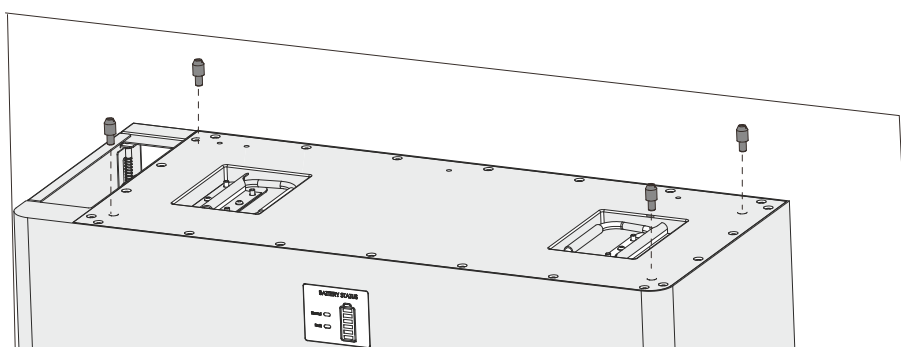

Step 3 Temporarily rest the retaining brackets in their respective positions on the battery module. Mark the position of the 2 holes to be made on the wall, then remove the two brackets.

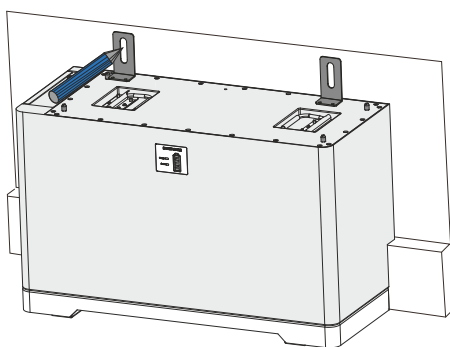

Step 4 Cover the support base and the battery module(s) with the shipping bag to avoid dust contamination. Drill two holes $\text{Ø} = 10\text{mm}$, depth = 60mm in the previously marked positions.



DANGER

Before drilling holes, check whether there are electrical pipes or other pipes buried in the walls to avoid risks.

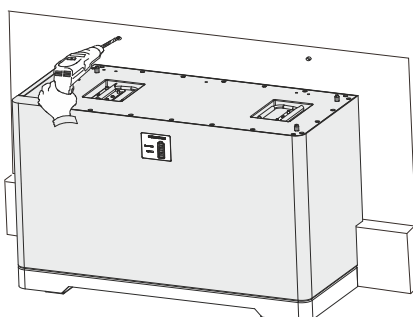

Step 5 Install the expansion tubes on the wall.

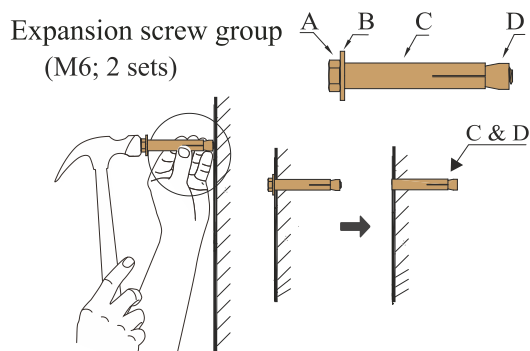

Step 6 Fasten the brackets to the battery with 4x M4 security screws supplied (tighten with a torque of 1.2Nm) and secure the brackets to the wall using the 2 expansion screws supplied (tighten with a torque of 2-2.5Nm).

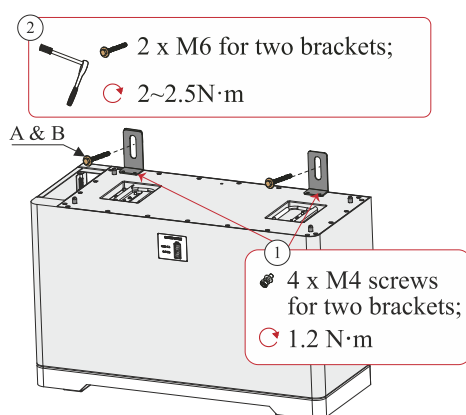

Step 7 Install the following battery pack according to step 1 and 2. Do not install more than 4 batteries on a single stack of modules.

Step 8 Fasten the grounding metal strap between every battery with 4x M4 security screws supplied (tighten with a torque of 1.2Nm).

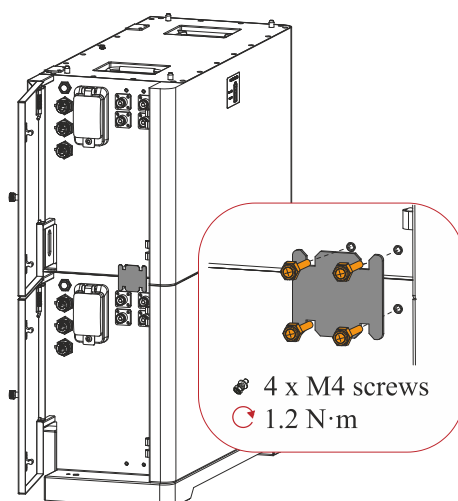

Step 9 Position the wall bracket on the battery module taking care to center the dedicated holes in the bracket with the locating pins on the battery. Temporarily fix the bracket with the jam screws and mark the position of the 6 holes to be drilled on the wall.

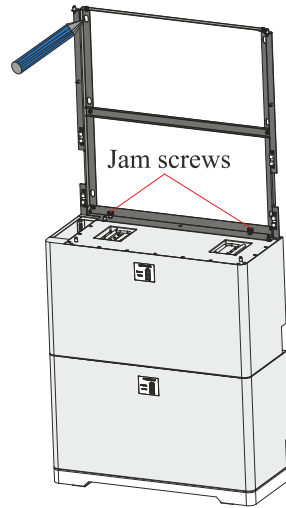

Step 10 Remove the mounting bracket, cover the batteries with the shipping bag to avoid dust contamination and then drill the six holes $\varnothing= 10\text{mm}$, depth = 60mm in the previously marked positions.

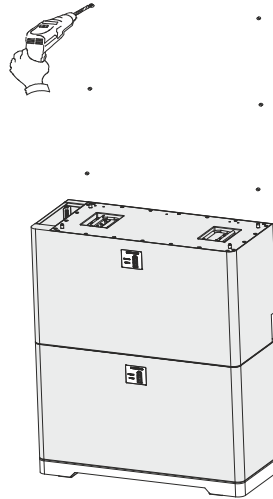

Step 11 Install expansion tubes as described in step 5. Secure the wall bracket to the battery with the 2 jam screws. Fasten 6x M6 expansion screws and the M4 security screw to secure the bracket in its position.

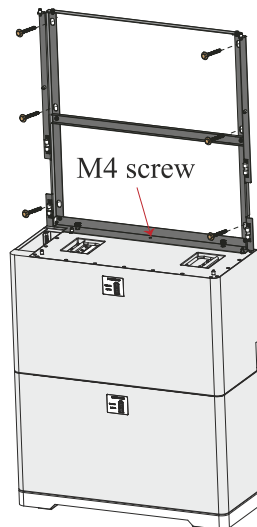

Step 12 Lift the inverter and tilt it backwards 10-15 degrees. Move it close to the locating pins on the bracket. Then lower the inverter while locating the locating pin guides into position.

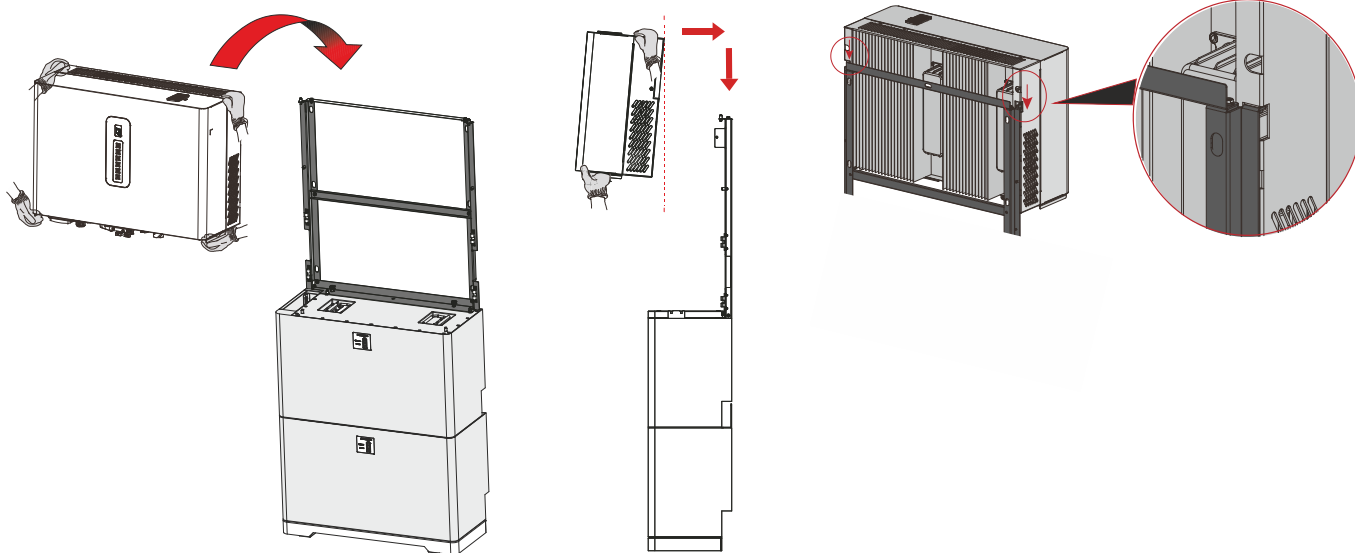

Step 13 Install the M4 security screw on the side of inverter (tighten with a torque of 1.2Nm).

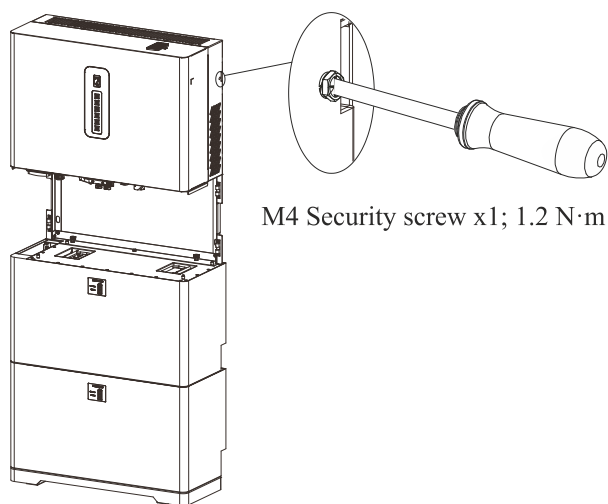

Side installation



For the side installation of the battery module, the "Side mounting kit" is needed.

Step 1 To install the support base and the battery modules, follow the instructions reported in the previous chapter (steps 1-8), for all the battery modules to be installed (max 4 battery modules on a single tower).

Step 2 Place the top cover on the upper battery module as shown in the picture below.

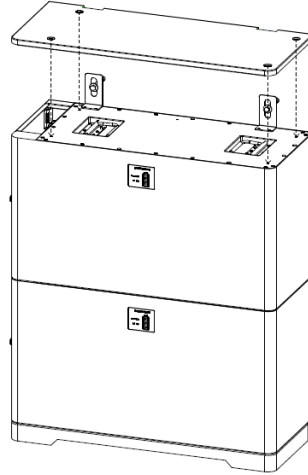

Step 3 Secure the top cover to the battery module with 4x M5 screws supplied.

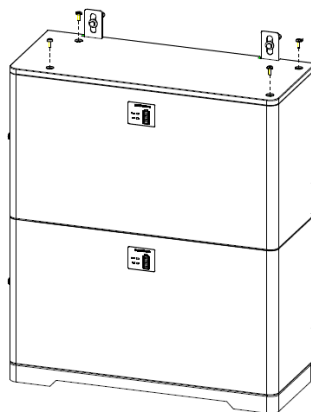

ELECTRICAL INSTALLATION

Preliminary operations

- It is advisable to install a circuit breaker on the AC grid side with rated current higher than 63A for RS 6.0 HYBRID, 40A for RS 3.6 HYBRID.
- It is advisable to install a circuit breaker on the critical load side with rated current higher than 40A for RS 6.0 HYBRID, 32A for RS 3.6 HYBRID.
- Turn off the PV switch and battery switch.
- Open every AC switch downstream of the inverter.

 DANGER	Before performing any electrical connections, ensure that all DC and AC switches are OFF. Otherwise, fatal injury can occur due to the high voltage generated by the inverter, grid or PV generator.
---	--

Hybrid inverter system connection diagram

The following image shows the connection diagram of a typical RS Hybrid system.

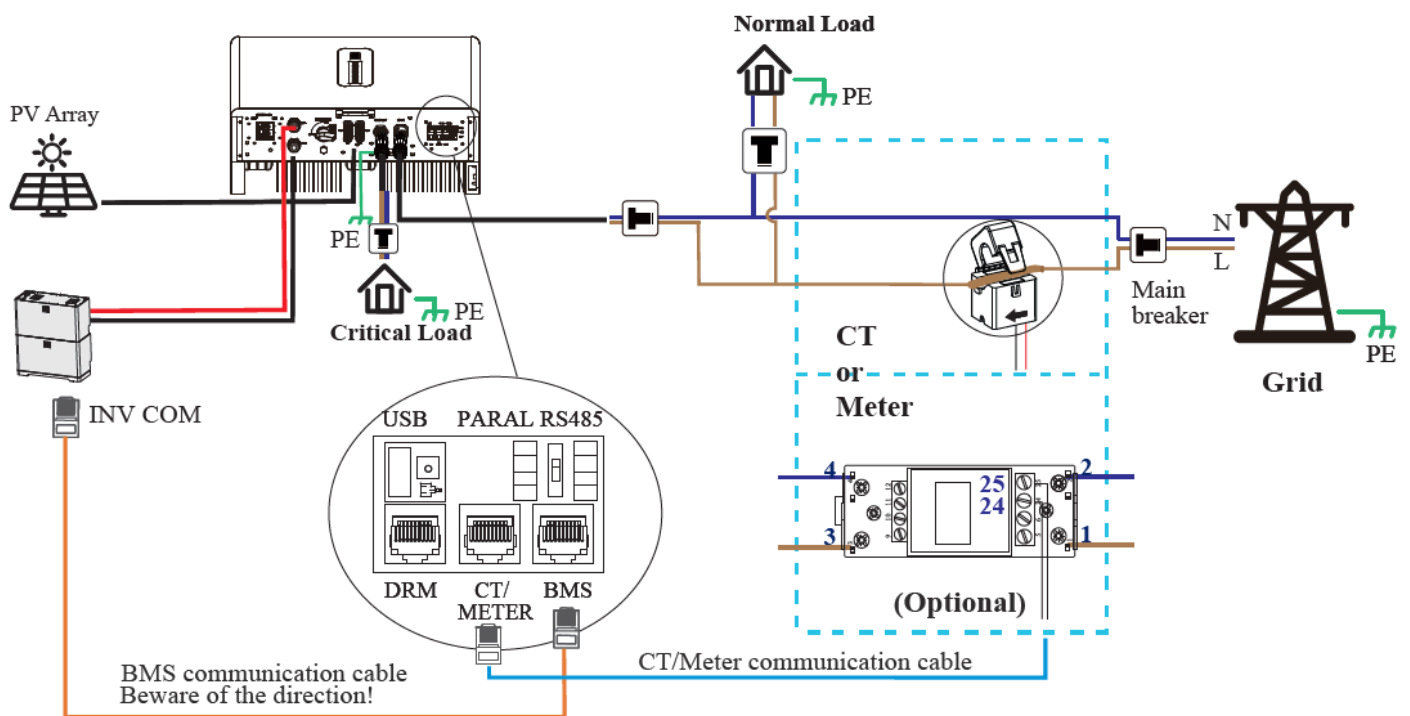





 NOTE	The energy meter (DDSU666) is optional and not included in the box. It can be used as an alternative for the current transformer (CT).
---	--

Connecting Protection Ground (PGND) cables

Preparation

The ground cable and OT terminals have to be prepared. A protective earth (PE) terminal is equipped at the side of the inverter. Please be sure to connect this PE terminal to the PE bar for reliable grounding. It is recommended to install AWG 10~12 (4~6 mm²) yellow-green lines as PE cables, in all cases the PE cables must have at least the same cross-section as the AC output cables.

 WARNING	The inverter must be grounded; otherwise, there is a risk of electric shock.
 CAUTION	If the positive or negative pole of the PV array is required to be grounded, then the inverter output to the AC grid must be isolated by an isolation transformer in accordance with IEC62109-1 and IEC62109-2 standards.
 NOTICE	Connecting External Protection Ground (PGND) Cables cannot substitute the connection of the PE cable from the AC power cables. Ensure that both connections are grounding well. Otherwise, warranty will be void if damage is caused by electrical connections fault.
 NOTE	Proper ground for the inverter helps to counter the impact of surge voltage and improve EMI performance. Connect the PGND cable before connecting the AC and DC power cables and the communication cables.
 NOTE	It is recommended that the ground cable is connected to a nearby ground position. For a system with multiple inverters connected in parallel, connect the inverters to the same ground point to ensure equipotential connections.

Wiring the PGND cable

Step 1 Remove an appropriate length of the insulation layer from the PGND cable using a wire stripper.

Step 2 Insert the exposed core wires into the crimping areas of the OT terminal and crimp them using hydraulic crimper.

Step 3 Install the OT terminal to the base support and to the grounding bar of the inverter using one M5 screw (not supplied) per terminal.

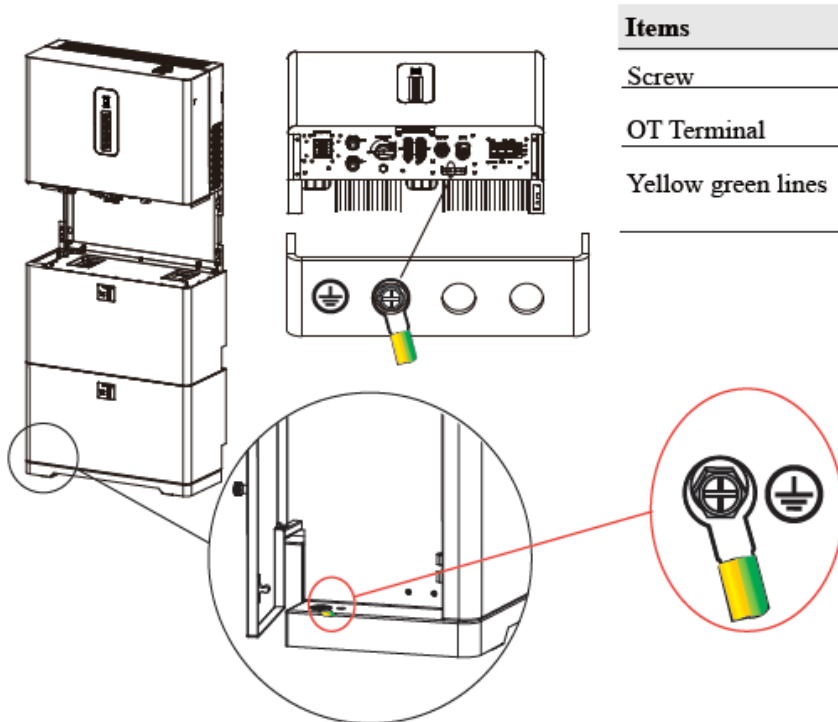

Items	Remark
Screw	M5 X 12mm; 2 N·m
OT Terminal	OT6-5
Yellow green lines	$S_{\text{(Yellow green lines)}} \geq S_{\text{(PE line of AC cable)}}$ S is the cross-sectional area.

Connecting the output cables

Preparing the cables

The subsequent table provides various information regarding the output cables depending on the inverter model and application.

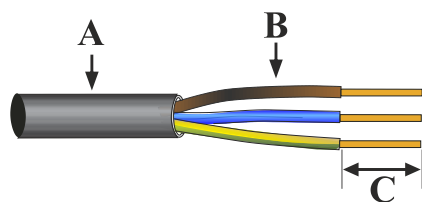

Model	Application	Diameter (A)	Cross-section (B)	Strip-length (C)
3.6	Grid output	10~14mm	4~6mm ²	~10mm
	Backup output	10~14mm	4~6mm ²	
6.0	Grid output	14~20mm	8~14mm ²	
	Backup output	10~14mm	4~6mm ²	

Connector assembly

Step 1 Insert the output wire into the nut and the connector's body.

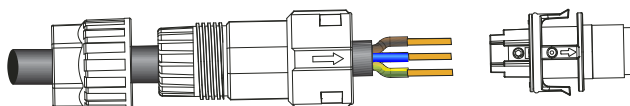

Step 2 Insert every wire into screw terminals according to the silkscreen on the connectors and the table below. Tighten each screw and ensure that no screw cap exceeds the surface.

Step 3 Plug the connector's end terminal into the body being careful to align the arrows until it clicks, then tighten the nut.

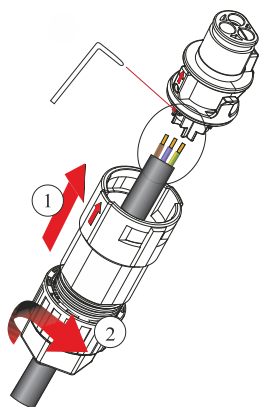

Grid (RS 6.0 HYBRID) Backup (all models)	Grid (RS 3.6 HYBRID)

Connection to the inverter

Insert the connectors in the corresponding ports until a click is heard.

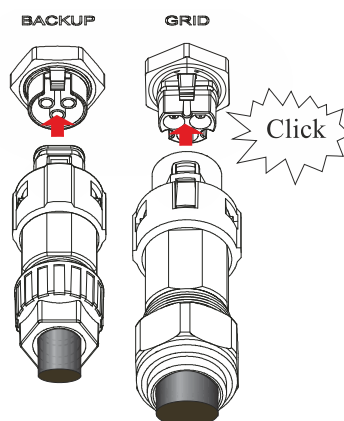





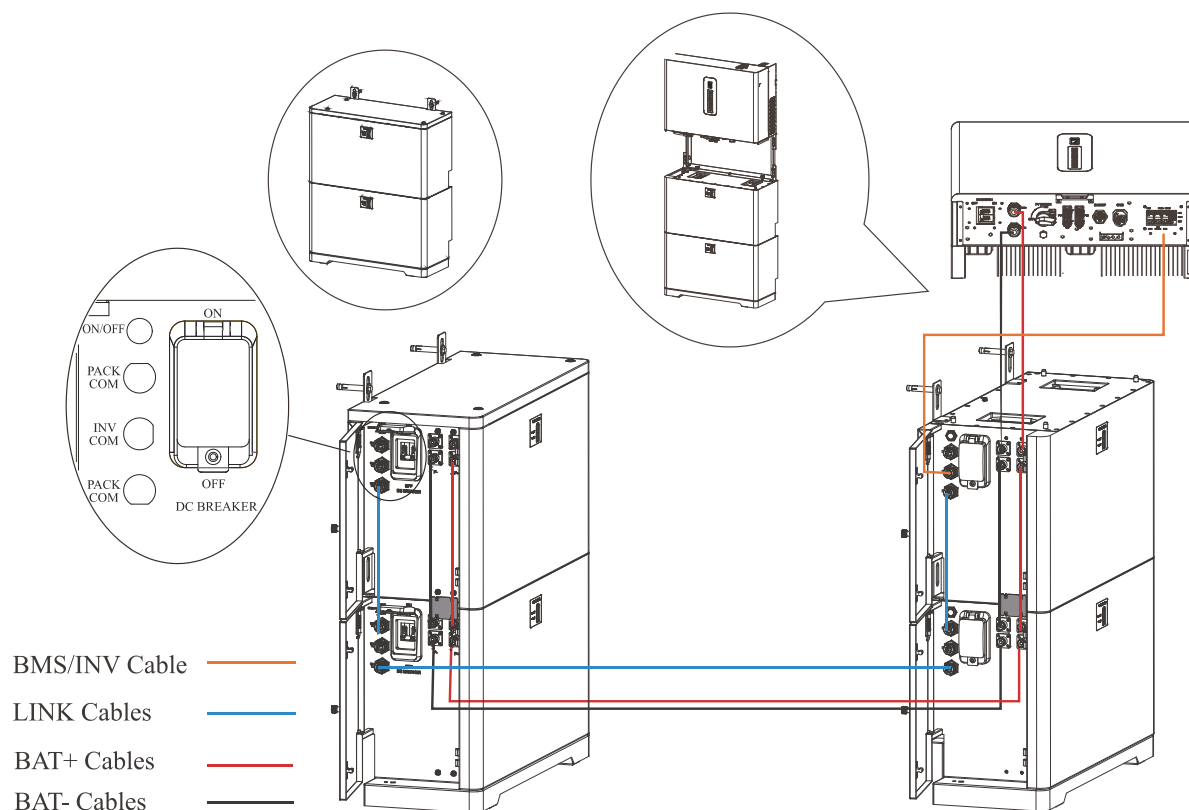

DANGER	Before connecting the grid and backup terminals, ensure that both the AC and DC part of the system are powered off; otherwise, there is a risk of high voltage electric shock.
DANGER	Before connecting the AC cable from inverter to AC breaker, you should confirm that the AC breaker is working normally. Turn off the AC breaker and keep it open until all connections are completed.
DANGER	Connect the PE conductor to grounding electrode and connect the neutral and live conductors to the AC breaker. Do not use a breaker only for the live wire, always use a double pole breaker.
NOTICE	Multiple inverters must have one breaker for inverter, never connect multiple inverters on a single AC breaker.
NOTICE	It is mandatory to connect the load between the grid and the inverter-side AC breaker, never connect the load directly to the inverter for maintenance purpose.















Connecting the batteries

The following image shows the battery connection diagram.



 WARNING	Beware of the polarity! The positive and negative cables can be swapped, and reverse polarity will damage the inverter!
 WARNING	When connecting lithium batteries, ensure that all DC switches are off. Never close the DC switches before connecting all LINK cables and powering up the BMS of every battery.
 WARNING	Be careful when manipulating the batteries: there is a risk of electric shock, and the batteries contain hazardous chemicals.
 WARNING	Only use supplied cables for connecting the batteries to the system. The use of unsuitable cables can lead to system malfunction or injuries.
 NOTICE	On some versions of the inverter, the BAT+/BAT- cables from the inverter to the first battery are embedded right into the inverter itself.
 NOTE	The secondary stack of batteries needs longer cables to meet the minimum clearance requirement of 500mm. These are part of the "RS HYBRID SIDE MOUNTING KIT".
 NOTE	The inverter must be connected to the BMS (Battery Management System) of the battery in order to properly work. Refer to the dedicated chapter for more informations.

Connecting the PV strings

 DANGER	The PV strings connection must comply with the following prerequisites; otherwise, an electric shock may occur.
 DANGER	PV modules generate electrical energy when exposed to sunlight and can create an electric shock hazard. Therefore, when connecting the PV modules, shield them with opaque cloth.
 DANGER	Before connecting the DC input power cables, ensure that the voltage on the DC side is within the safe range and that the DC SWITCH on the inverters is OFF. Otherwise, high voltage may result in electrical shock.
 DANGER	When the inverter is grid-tied, it is not allowed to maintain DC input power cables, such as those used to connect or disconnect a string or a module in a string. Only after the inverter enters in shutdown mode can maintenance on the DC input power cables be performed.
 WARNING	Grounding of the PV strings must comply with the following prerequisites; otherwise, a fire can break out.
 WARNING	PV modules connected in series in each PV string must have the same specifications.
 WARNING	The maximum open-circuit voltage of each PV string must be always lower than or equal to its permitted range.
 WARNING	The maximum short-circuit current of each PV string must be always lower than or equal to its permitted range.
 WARNING	The positive and negative terminals of PV modules must be connected to the positive and negative DC input terminals of the inverter, respectively.
 WARNING	During the installation of PV strings and the inverter, the positive or negative terminals of PV strings cannot be short-circuited.
 CAUTION	It is recommended to use dedicated PV1-F cable for PV connections, with a cross-section of 4~6mm ² .
 NOTICE	Before connecting the PV panels, make sure the plug connectors have the correct polarity. Incorrect polarity could permanently damage the inverter.
 NOTICE	PV arrays shouldn't be connected to the grounding conductor.
 NOTICE	The minimum insulation resistance to ground of the PV panels must be higher than 18.33k Ω . If the resistance is lower than this value, there is a risk of shock hazard.

Cable preparation

Step 1 Remove an adequate length of insulating layer from the positive and negative power cables using a wire stripper, as shown in below image.

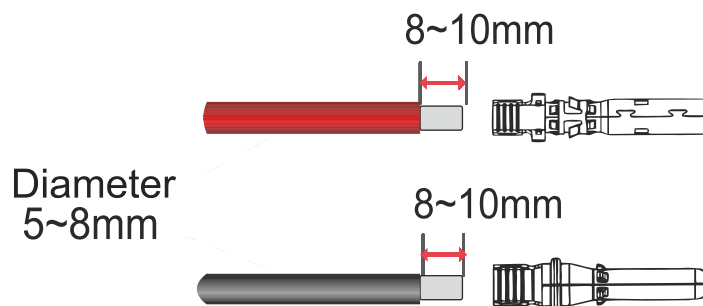

Step 2 Insert the exposed areas of the positive and negative cables into the metal terminals of the positive and negative connectors respectively and crimp them using a crimping tool.

Use crimping tool on the zone indicated by the arrows to crimp. Do not crimp the zone circled in red.

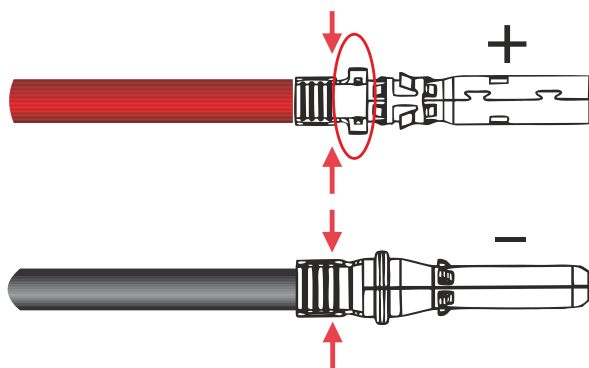

Step 3 Insert the crimped positive and negative cables into the corresponding positive and negative connectors. Tighten the waterproof nuts on each connector with an appropriate tool.

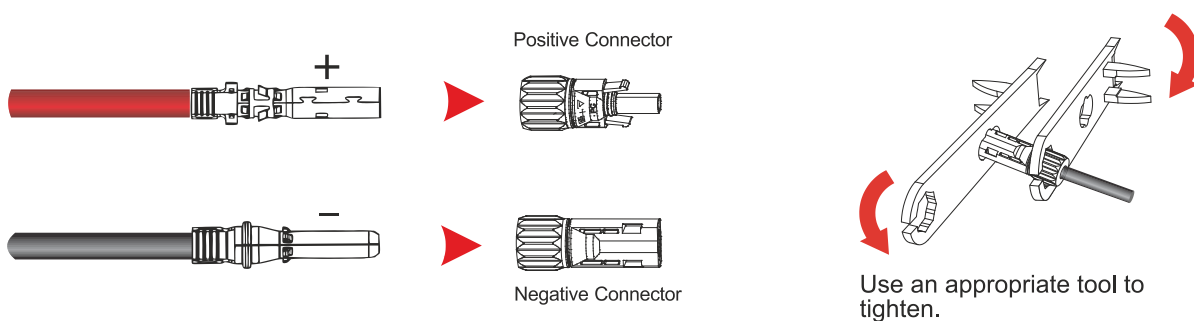

Step 4 Test string voltage and confirm polarity. Ensure that the DC switch is OFF before step 5.

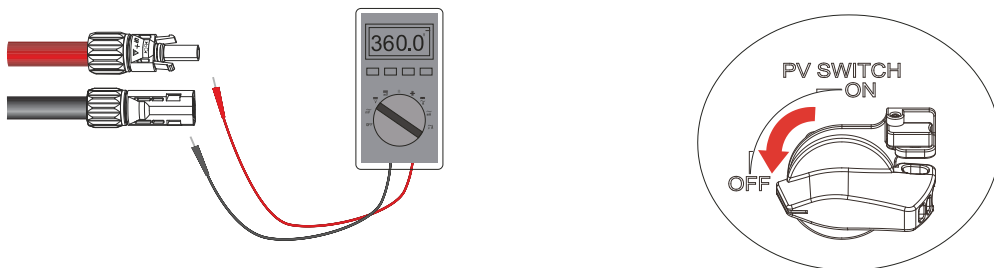

Step 5 Insert positive and negative connector in PV+/PV- port respectively until a “click” sound is heard.

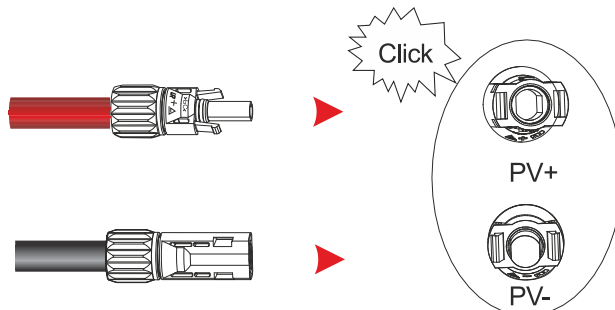

Connecting the CT or Energy Meter (optional)

The inverter can operate using a Current Transformer (CT, supplied) or an Energy Meter (optional, not supplied), alternatively. Before the connection to the grid, install a separate AC breaker with a current capacity of at least 60A between the grid and the CT/Energy Meter. This ensures that the inverter can be safely disconnected during maintenance.

CT Connection

The connection diagram of power cable and CT is shown in the figure below:

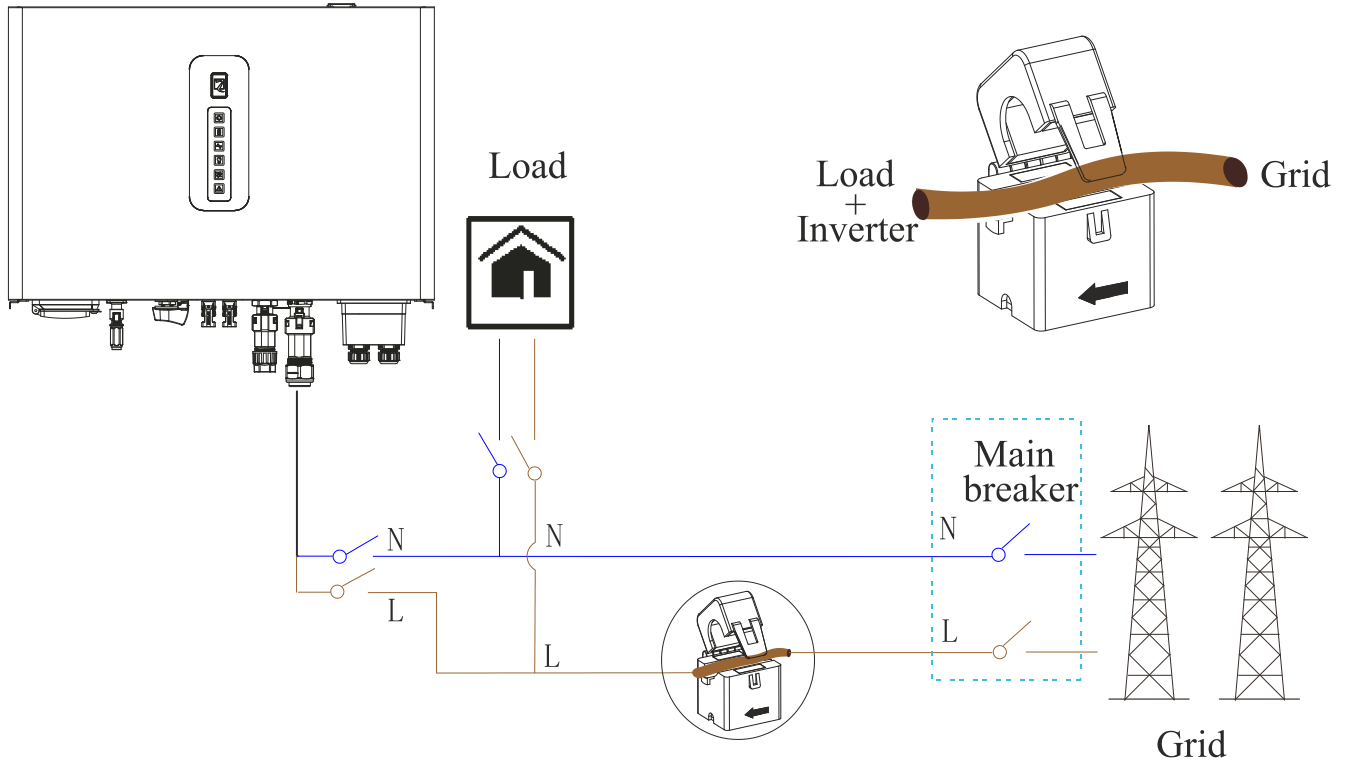

The Current Transformer has an arrow which indicates the current direction. It can be clamped in both directions, but it is important to set the CT direction in the app according to the installation.

Connection to the inverter

The CT is meant to be directly connected to the inverter, using the METER/CT RJ45 port, as shown below.

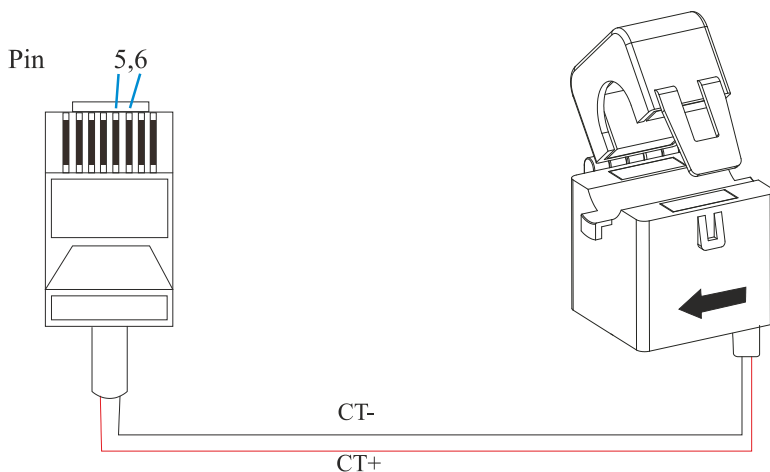

RJ45 connector	CT
Pin5 (CT-)	Black
Pin6 (CT+)	Red

Energy Meter Connection

The inverter supports the DDSU666 Energy Meter manufactured by CHINT, which is not included in the box. The next figure shows the terminals needed to connect the Energy Meter to the system.

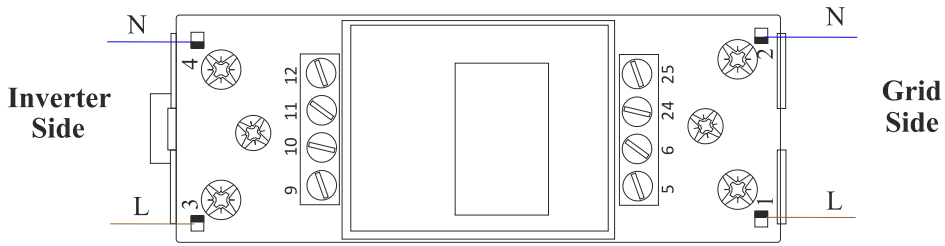

The following image shows how the energy meter is to be connected to the system.

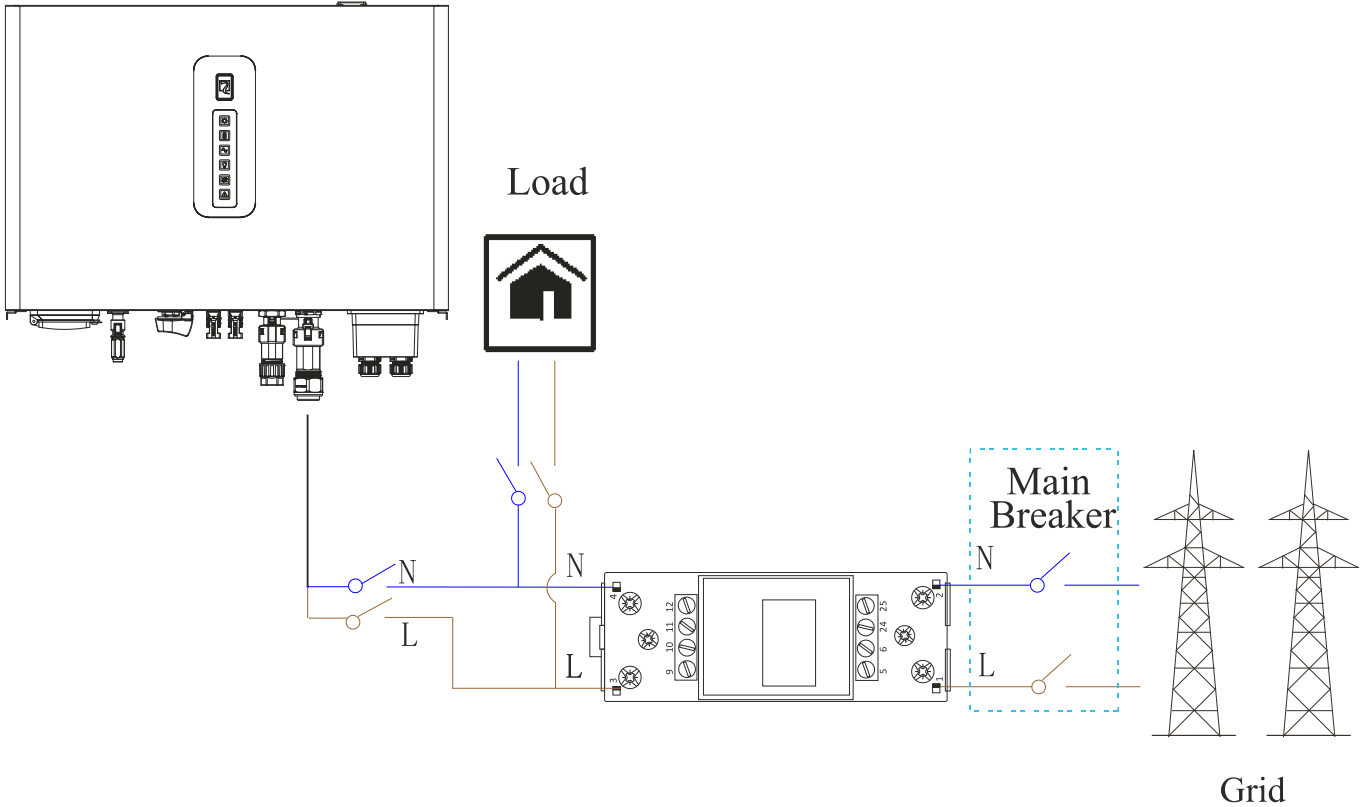

Connection to the inverter

The Energy Meter connects to the inverter using the same RJ45 cable as the Current Transformer (CT). The next picture shows the intended connection method.

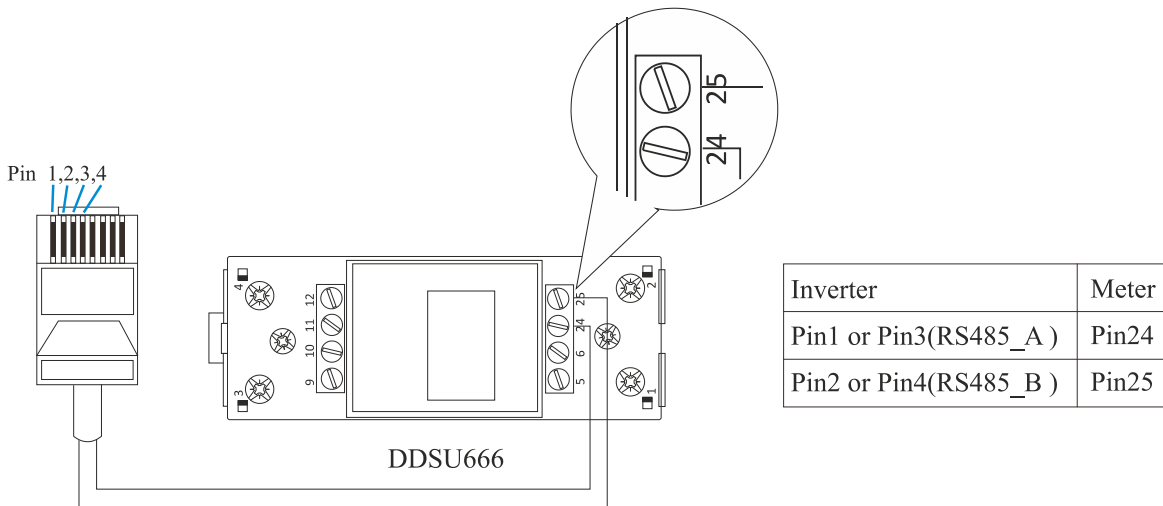

Connecting the Battery Management System

It is mandatory to connect the battery BMS (Battery Management System) to the inverter to properly charge and discharge the battery. The BMS gets connected to a dedicated RJ45 connector, whose pinout is shown below.

RJ45 Connection Pinout

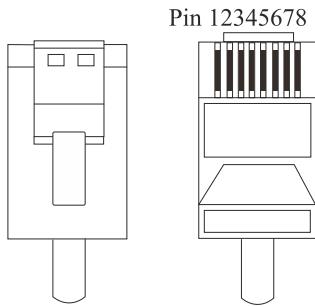

Pin	1	2	3	4	5	6	7	8
Signal	RS485_A	RS485_B	GND_S	GND_S	GND_S	GND_S	CAN_L	CAN_H

Connecting the DRM (for inverters installed in Australia)

All inverters installed in Australia must have a DRM (short for Demand Response Mode) to meet the local rules.

RJ45 Connection Pinout

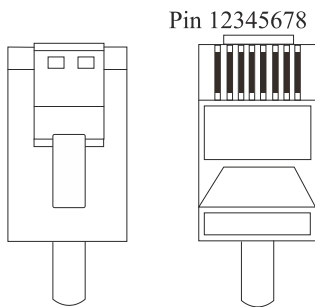

Pin	1	2	3	4	5	6	7	8
Signal	DRM1/5	DRM2/6	DRM3/7	DRM4/8	REF	DRM0/COM	NC	NC



NOTE

The DRM function has to be activated on the inverter via the app.

Connecting the RS485 Interface

All inverters have a General Purpose RS485 Interface that can be used to connect an external datalogger or other equipment.

RS485 Connector Pinout

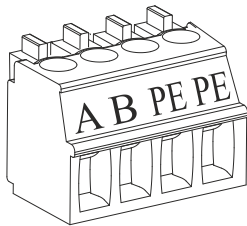

Pin	A	B	PE	PE
Signal	RS485_A	RS485_B	PE	PE

NTC/RMO/DRY Connections

Pinout

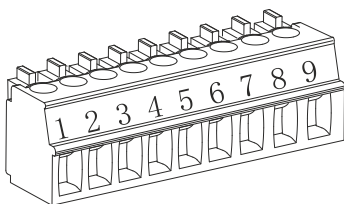

Pin	1	2	3	4	5	6	7	8	9
Signal	NO1	N1	NC1	NO2	N2	NC2	External signal	GND S (NTC BAT)	Remote off

Communication interfaces

The image below shows the communication interfaces in the communication port on the bottom of the inverter.

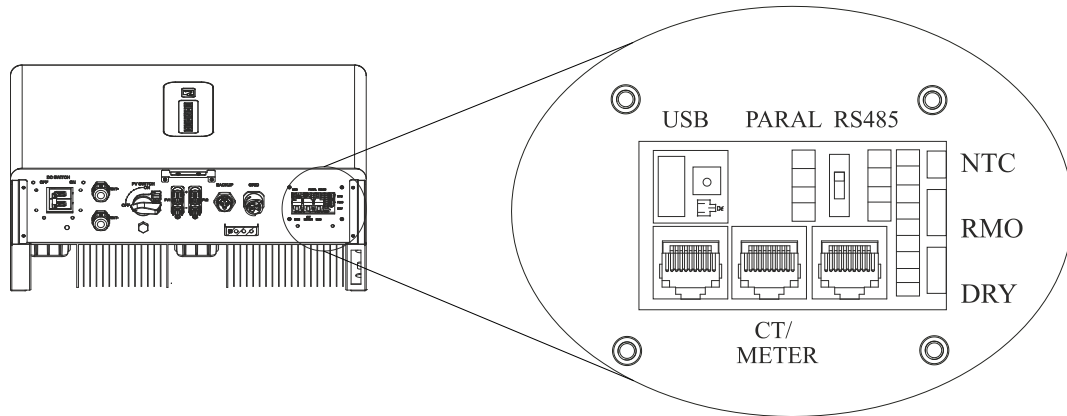

Interface		Description
USB		For firmware upgrade
PARAL		4-pin interface for multiple inverters operation with switch for terminating resistor.
RS485		4-pin interface for RS485 communication
DRM		RJ45 interface for Demand Response Mode (for Australia applications)
CT/METER		Interface for Energy Meter or Current Transformer (CT)
BMS		Interface for Battery Management System communication
9-pin Interface	pins 1-6	Reserved
	pins 7-8	"External signal" input (for CEI 0-21 regulation)
	pins 8-9	"Remote OFF" input (for CEI 0-21 regulation)

Securing the connections' waterproof cover

Step 1 Unscrew the rubber nuts from the cover and remove the seals.

Step 2 Insert all the cables into the rubber nuts and press them into the seals via the side incisions as shown in the image below.

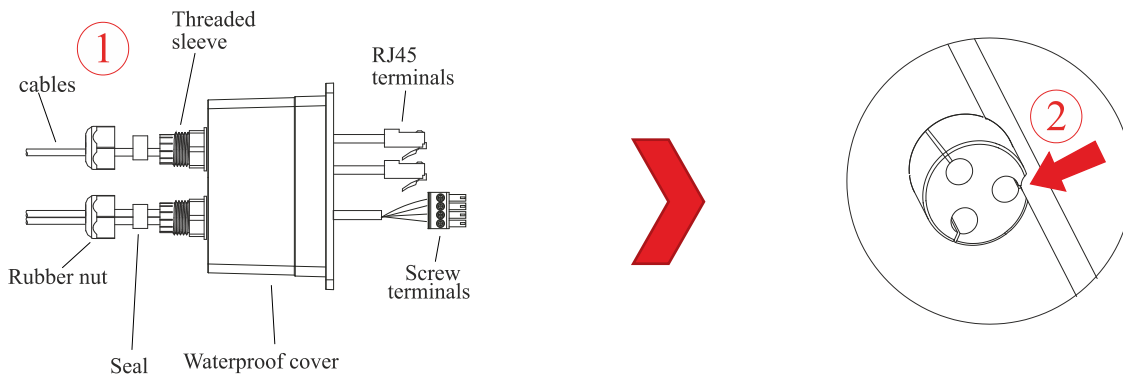

Step 3 Insert every connector in its designated interface at the inverter's side

Step 4 Screw the waterproof cover back to the inverter with 4 M4 screws (included)

Step 5 Install the seal inside the threaded sleeve and then screw the rubber nut in position.

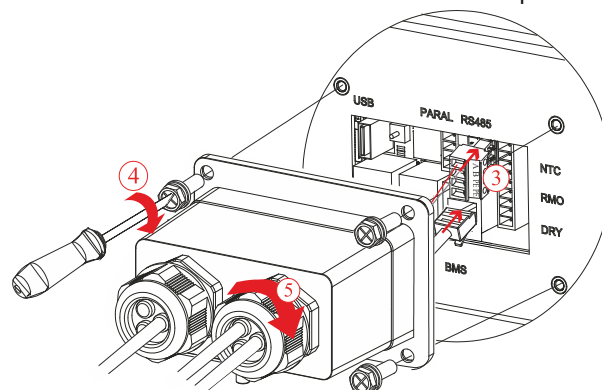

Connecting the Wi-Fi Module

Step 1 Loosen the two screws that keep the cover installed on top of the inverter.

Step 2 Insert the Wi-Fi module into the port.

Step 3 Secure the module with 2 M4 screws (included).

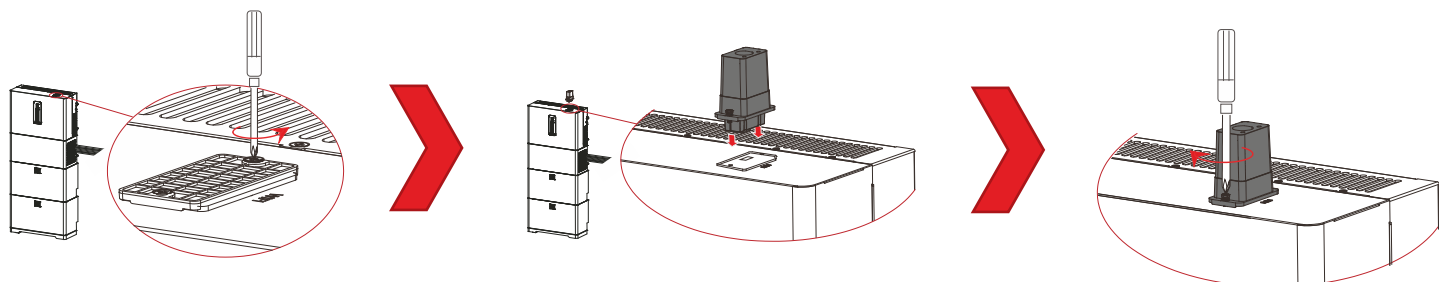

Installing the cable cover

Install the cable cover onto the inverter's bracket by pushing it into position. Note that all the cables must exit in the same way and that the groove of the cable cover must be in the same direction of the cables' outlet.

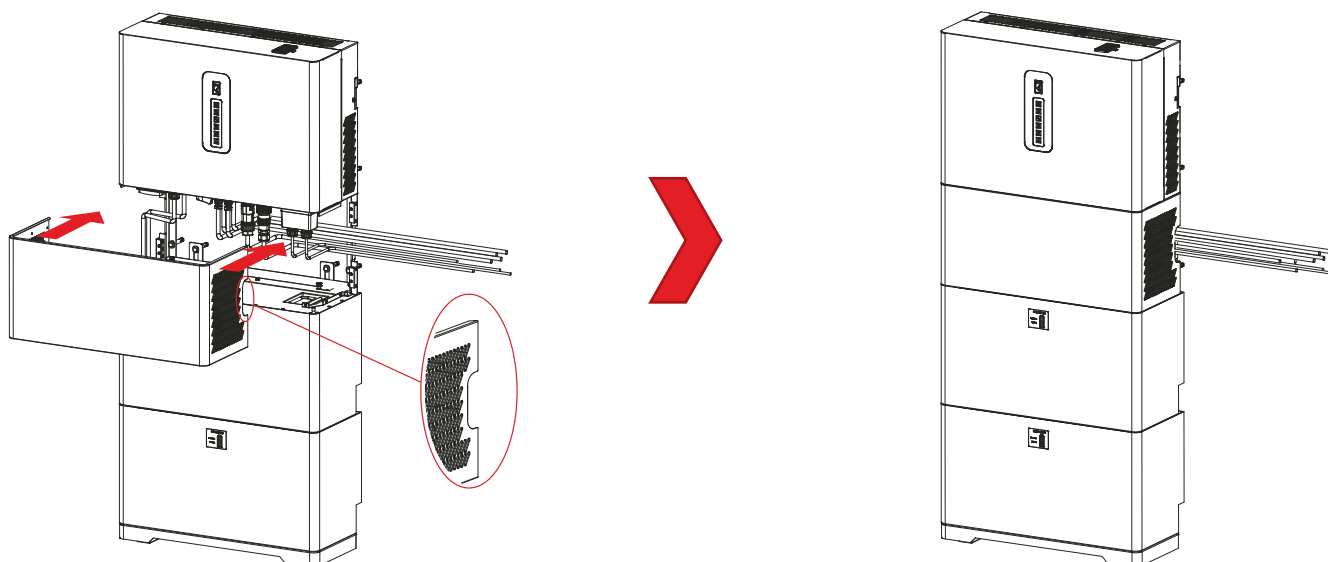

Installation self-check

It is mandatory to verify the inverter installation. This is to avoid electric shock, fire risks, other injuries or faults. Once the inverter has been installed, check the following items:

- Ensure that the inverter is firmly installed.
- Ensure that there is enough space for ventilation.
- Ensure that there is no other object on the PV inverter.
- Ensure that the installation has been made with maintenance in mind.
- Ensure that all screws are tight, especially those used for electrical connections.
- Ensure that every connection is right, including the absence of short-circuits and open circuits.
- Ensure that the waterproof nuts are tight.
- Ensure that the cover plate is properly installed.
- Ensure that every unused connector is covered with fireproof and waterproof materials.
- Ensure that all safety and warning labels are intact and complete.

SYSTEM OPERATION

Powering the inverter on

The image below shows the start-up procedure for the hybrid inverter system.

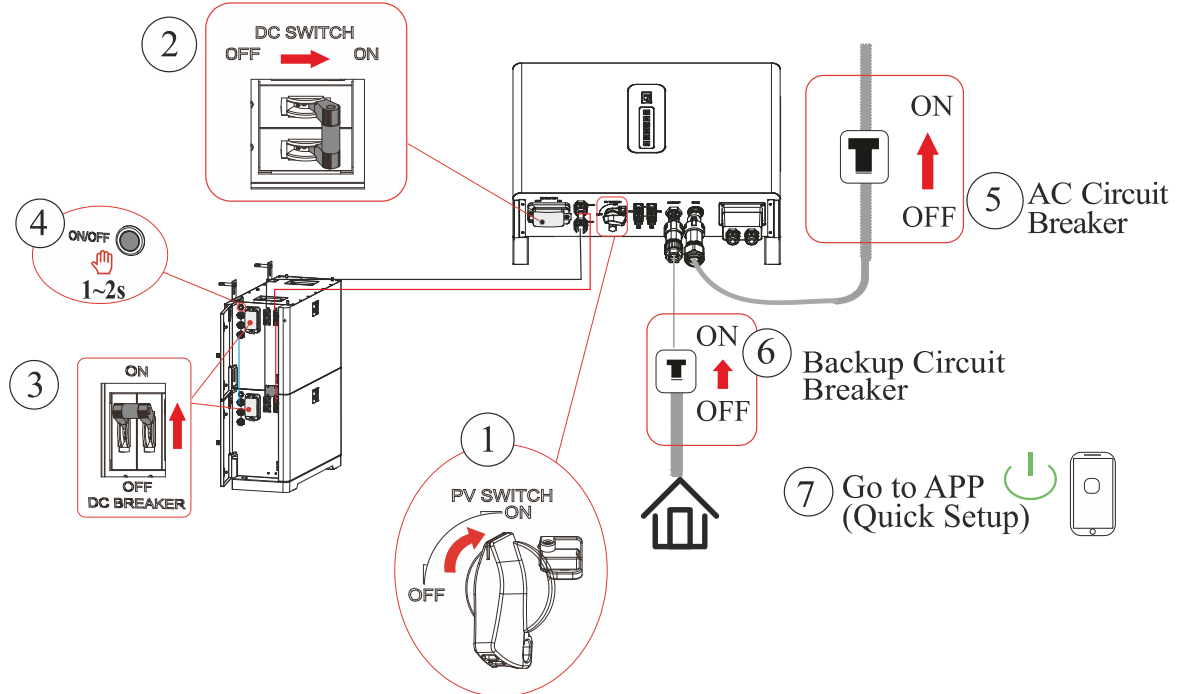

Step 1 Close the PV switch on the inverter.

Step 2 Close the DC switch (batteries) on the inverter.

Step 3 Close the DC switch on every battery pack.

Step 4 Push the power button on one battery pack for 1~2 seconds. All other batteries should wake up at the same time.

Step 5 Close the inverter-side grid AC breaker.

Step 6 Close the backup AC breaker.

Step 7 Connect the smartphone App via Bluetooth. Refer to the appropriate section for details. Power on the inverter in the quick setup section.

Commissioning

After the installation, it is necessary to make a complete commissioning of the inverter system. This is to ensure that the system will perform as intended and also to maintain a high level of security.

After installation self-check, perform the subsequent operations:

Step 1 Power on the system as explained before.

Step 2 After connecting the smartphone App via Bluetooth, set all parameters on the app according to user's requirement or local rules.

Step 3 Complete the system installation by removing any temporary materials or tools.

Step 4 Open the inverter-side grid AC breaker and the back-up AC breaker.

Step 5 Charge the batteries to 100% using solar power, when charged keep them in charge for at least 8 hours.



NOTICE

This step is essential in order to ensure a sufficient service life of the battery. Failure to follow these steps could lead to poor battery performance and/or malfunctioning.

Step 6 Close the inverter-side grid AC breaker and the back-up AC breaker.

Powering the inverter off

The image below shows the power-off procedure for the hybrid inverter system.

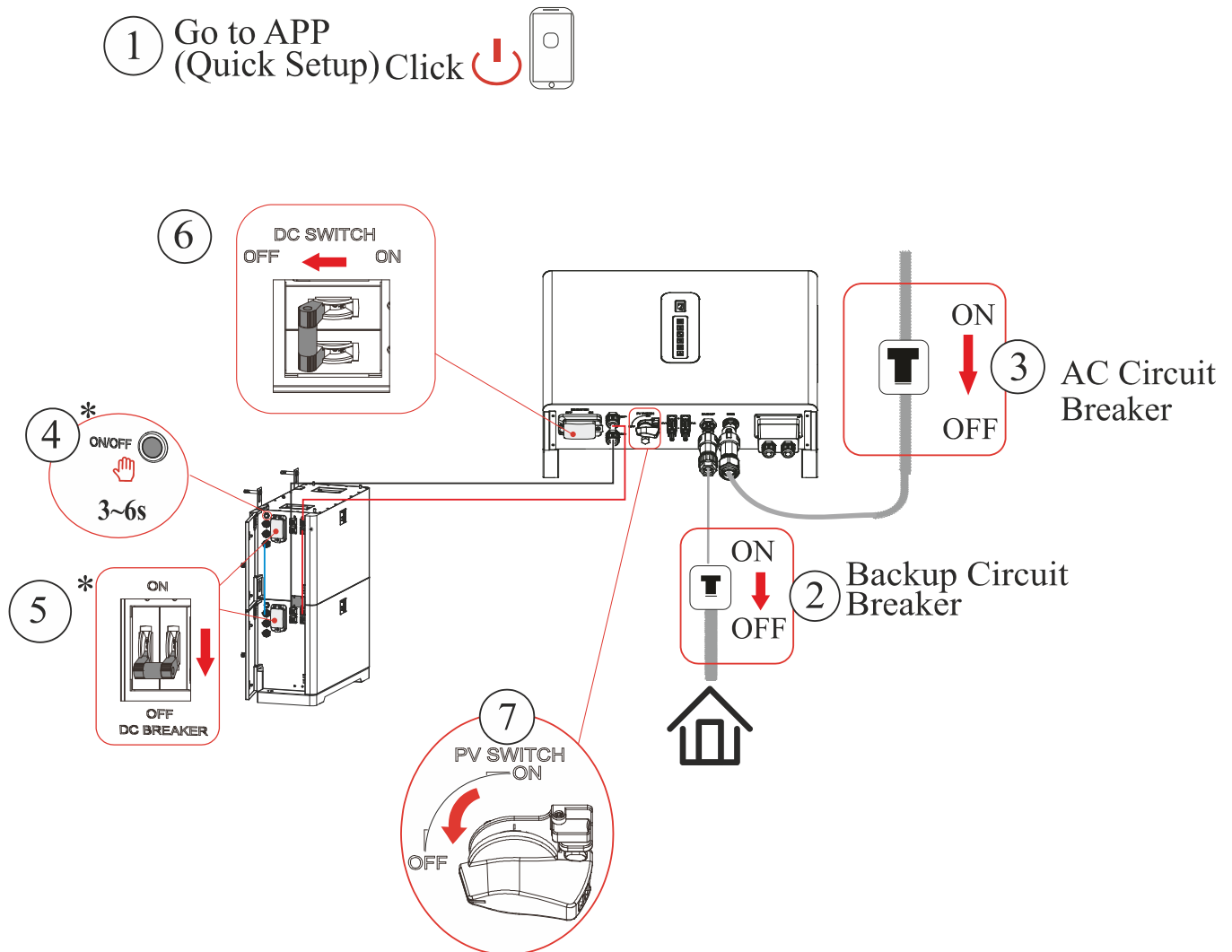

Step 1 Connect the smartphone App via Bluetooth. Refer to the appropriate section for details. Power off the inverter in the quick setup section.

Step 2 Open the backup AC breaker.

Step 3 Open the inverter-side grid AC breaker.

Step 4 Push the power button on the battery closest to the inverter for 3~6 seconds. All other batteries should shut down at the same time.

Step 5 Open the DC switch on every battery pack.

Step 6 Open the DC switch (batteries) on the inverter.

Step 7 Open the PV switch on the inverter.







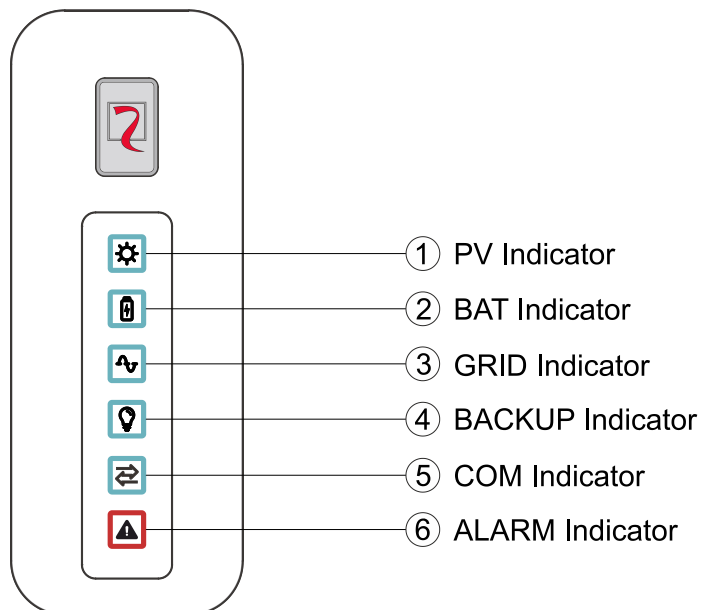

WARNING

After the inverter switches off, the remaining electricity and heat may still cause electrical shock and burns. Wait five minutes after the power-off before servicing the inverter.

USER INTERFACE

The indicator panel of the inverter is composed of six LED indicators. The LED indicators include the PV, BAT, GRID, BACKUP, COM and ALARM indicators.



LED Indicator	Status	Description
PV 	On	PV Input is available and normal.
	Blinking	PV Input is available but abnormal.
	Off	PV Input is unavailable.
BAT 	On	Battery is charging or in stand-by.
	Blinking slow	Battery is discharging.
	Double flash	Battery is abnormal.
	Off	Battery is unavailable.
GRID 	On	Grid is available, connected and normal.
	Blinking	Grid is available but abnormal.
	Blinking fast	Connecting to the grid...
	Off	Grid is unavailable.
BACKUP 	On	Backup power is available and normal.
	Double flash	Backup power is abnormal.
	Off	Backup power is disabled.
COM 	On	Wi-Fi OK, Router OK, Internet OK.
	Blinking	Wi-Fi OK, Router OK, Internet abnormal.
	Blinking fast	Sending data...
	Off	Wi-Fi is not connected.
ALARM 	On	Fault occurred and inverter shuts down.
	Blinking	Fault occurred but inverter still on.
	Off	No Fault.

LED Status and Warning Code Table

Alarm name	Alarm Code	LED State					
		PV	GRID	BAT	BACKUP	COM	ALARM
PV abnormal		●	◎	◎	◎	◎	○
No PV		○	◎	◎	◎	◎	○
PV over voltage	B0						
PV under voltage	B4						
PV irradiation weak	B5	★	◎	◎	◎	◎	○
PV string reverse	B7						
PV string abnormal	B3						
On grid		◎	●	◎	◎	◎	○
Grid absent	A2	◎	○	◎	◎	◎	○
Grid over voltage	A0						
Grid under voltage	A1						
Grid over frequency	A3						
Grid under frequency	A4	◎	★	◎	◎	◎	○
Grid abnormal	A6						
Grid over mean voltage	A7						
Neutral live wire reversed	A8						
Battery charging		◎	◎	●	◎	◎	○
Battery standby		◎	◎	●	◎	◎	◎
Battery absent	D1	◎	◎	○	◎	◎	○
Battery discharging		◎	◎	★	◎	◎	○
Battery under voltage	D3						
Battery over voltage	D2						
Battery discharge overcurrent	D4						
Battery over temperature	D5	◎	◎	★★	◎	◎	○
Battery under temperature	D6						
Communication loss (Inverter-BMS)	D8						
Backup output active		◎	◎	◎	●	◎	◎
Backup output inactive		◎	◎	◎	○	◎	◎
Backup short circuit	DB						
Backup overload	DC						
Backup output voltage abnormal	D7	◎	◎	◎	★★	◎	○
Backup over dc-bias voltage	CP						
Inverter over temperature	C5						
Fan abnormal	C8						
Inverter in power limit state	CL						
Data logger lost	CH	◎	◎	◎	◎	◎	★
Meter lost	CJ						
Remote off	CN						
PV insulation abnormal	B1						
Leakage current abnormal	B2						
Internal power supply abnormal	C0						
Inverter over DC-bias current	C2						
Inverter relay abnormal	C3						
GFCI abnormal	C6						
System type error	C7						
Unbalance DC-link voltage	C9						
DC-link over voltage	CA	◎	◎	◎	◎	◎	●
Internal communication error	CB						
Internal communication loss (E-M)	D9						
Internal communication loss (M-D)	DA						
Software incompatibility	CC						
Internal storage error	CD						
Boost abnormal	CG						
DC-DC abnormal	CU						

Note: ● light fixed on ○ light off ★ light blinking ◎ keep original status ★★ double flash

Battery pack LED

Each battery pack is equipped with 8 LEDs showing the status and charge of the pack itself.

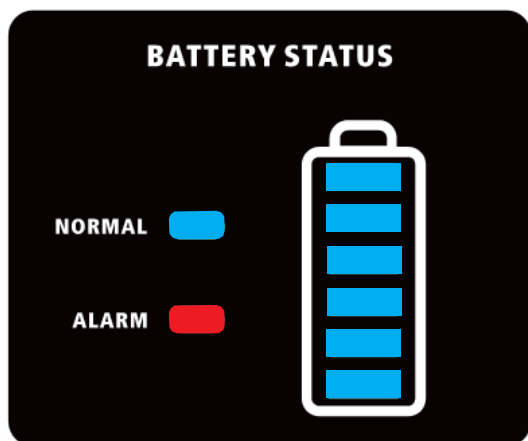

Items		Normal	Alarm	Battery Level Indicator						Descriptions
Status		L8	L7	L6	L5	L4	L3	L2	L1	
Shutdown		OFF	OFF	OFF	OFF	OFF	OFF	OFF	OFF	All OFF
Standby		ON	OFF	According to battery level						Same as normal discharge
Charging	Normal	ON	OFF	According to battery level, the highest LED blinks.						
	Fully charged	ON	OFF	ON	ON	ON	ON	ON	ON	
	Protection	OFF	ON	OFF	OFF	OFF	OFF	OFF	OFF	Stop charging
Discharging	Normal	ON	OFF	According to battery level						
	Empty	Flash	OFF	OFF	OFF	OFF	OFF	OFF	OFF	
	Protection	OFF	ON	OFF	OFF	OFF	OFF	OFF	OFF	Stop discharge
Alarm		OFF	ON	OFF	OFF	OFF	OFF	OFF	OFF	Stop charging and discharge

Battery Level Indicators

Status		Charge						Discharge					
Light		L6	L5	L4	L3	L2	L1	L6	L5	L4	L3	L2	L1
Capacity	0~17%	OFF	OFF	OFF	OFF	OFF	Blink	OFF	OFF	OFF	OFF	OFF	ON
	18~33%	OFF	OFF	OFF	OFF	Blink	ON	OFF	OFF	OFF	OFF	ON	ON
	34%~50%	OFF	OFF	OFF	Blink	ON	ON	OFF	OFF	OFF	ON	ON	ON
	51%~66%	OFF	OFF	Blink	ON	ON	ON	OFF	OFF	ON	ON	ON	ON
	67%~83%	OFF	Blink	ON	ON	ON	ON	OFF	ON	ON	ON	ON	ON
	84%~100%	Blink	ON	ON	ON	ON	ON	ON	ON	ON	ON	ON	ON

Blink and flash patterns

Pattern	Behaviour
Blink	0.5 s OFF, 0.5 s ON
Flash	2 s OFF, 0.5 s ON

WORKING MODE

The inverter supports several different working modes, described below.

1) Self-used mode

Under self-used mode, the priority of PV energy will be Load > Battery > Grid, that means the energy produced by PV gives priority to local loads, excess energy is used for charging the battery, and the remaining energy is fed into the grid. This is the default mode to increase self-consumption rate. There are several situations of self-used working mode based on PV available energy, as shown below.

a. Wealthy PV Energy

When PV energy is wealthy, the PV energy will first be consumed by loads, the excess energy will be used to charge the battery, then the remaining energy (if any) will be fed into the grid.

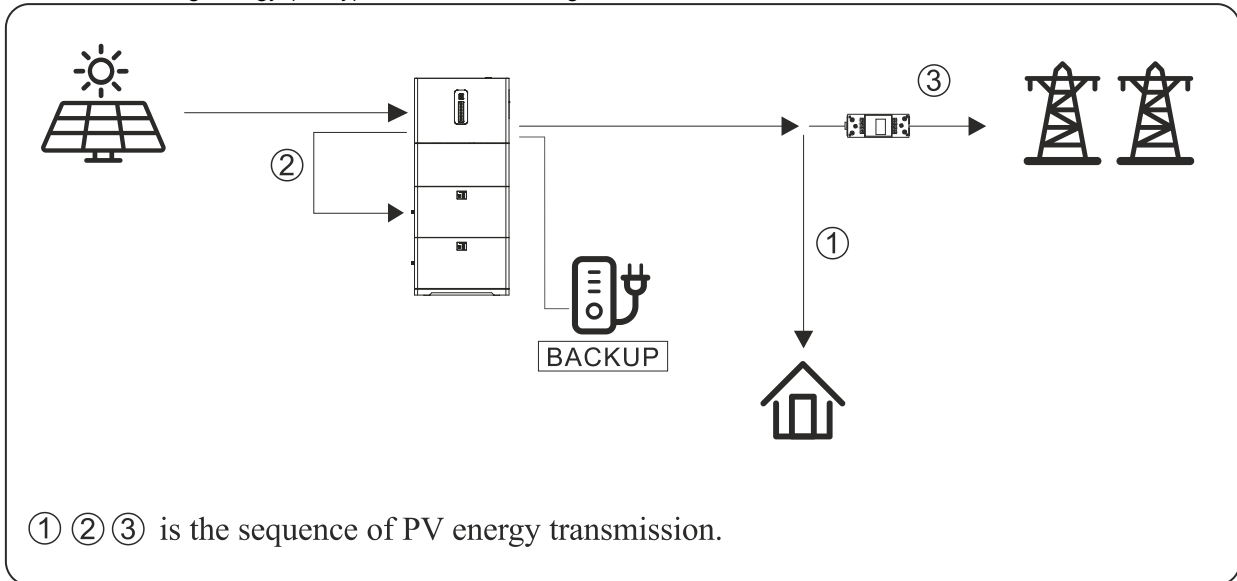

b. Limited PV power

When the PV energy is not enough to cover all the loads, all the PV energy will be used for load, and the insufficient part will be supported by the battery. If there is still insufficient power the load will be supported by grid.

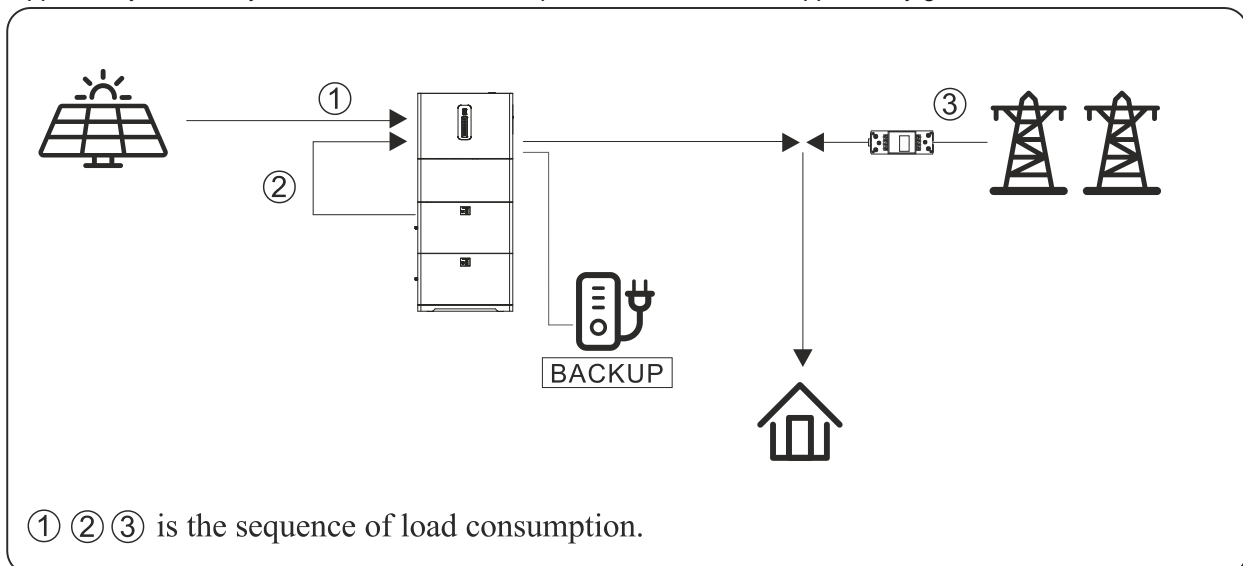

c. No PV power

When there is no PV power from the strings, the inverter will first discharge the battery energy to power the loads. If the demand is not met, then it will consume power from the grid.

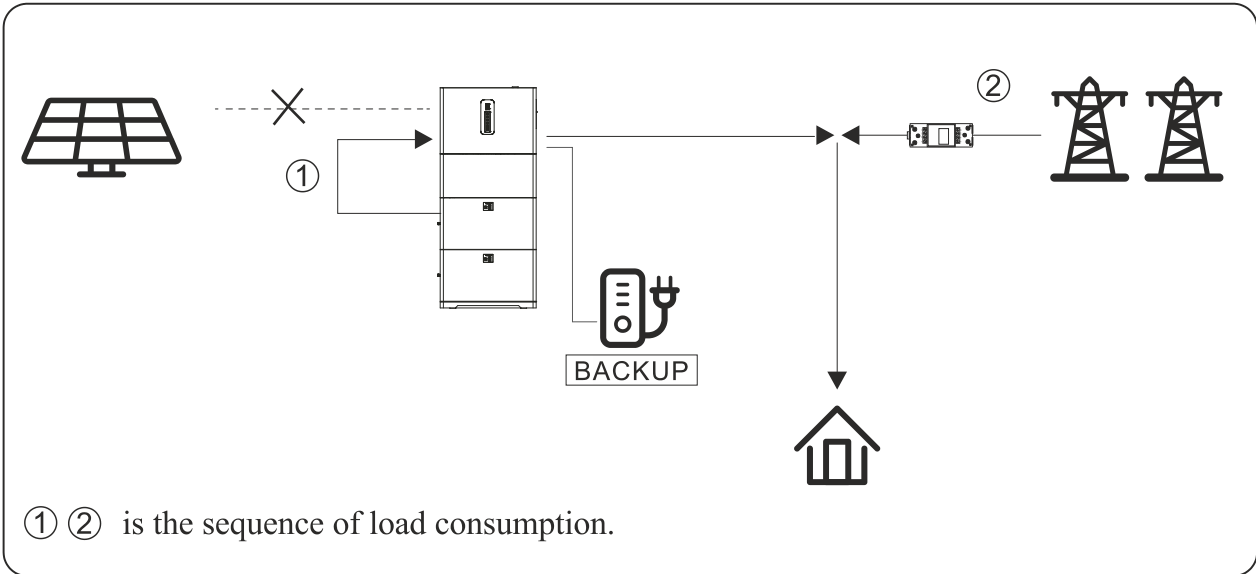

2) Feed-in Priority mode

Under feed-in priority mode, the priority of PV energy will be Load > Grid > Battery, that means the energy produced by PV gives priority to local loads, excess energy is fed into the grid, and the remaining energy is used for charging the battery.

a. Wealthy PV Energy

When PV energy is wealthy, the PV energy will be first consumed by loads, if there is excess PV power, then the excessive power will be fed into grid. If there is still PV energy rested after load consuming and grid feeding, then the rested PV power will be used to charge the battery. The grid feeding maximum power can be either the maximum output power of the inverter or a custom value set by the user or installer.

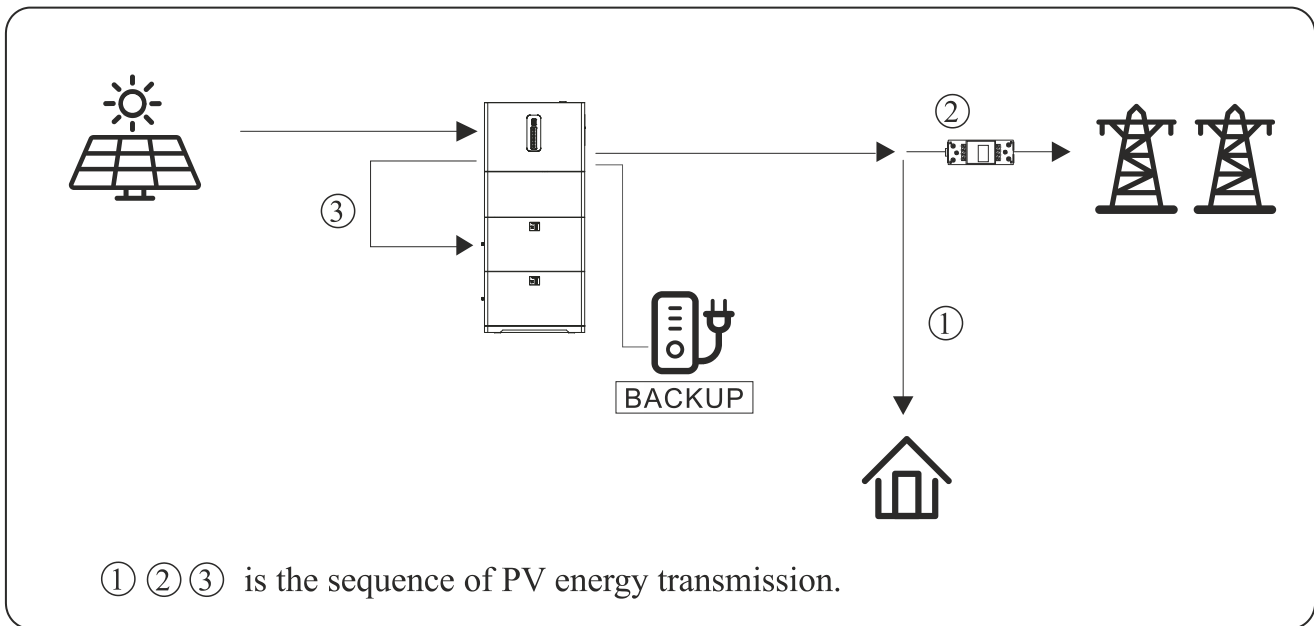

b. Limited PV Energy

When PV energy is limited and cannot meet the feed-in grid power, the battery will discharge to meet it.

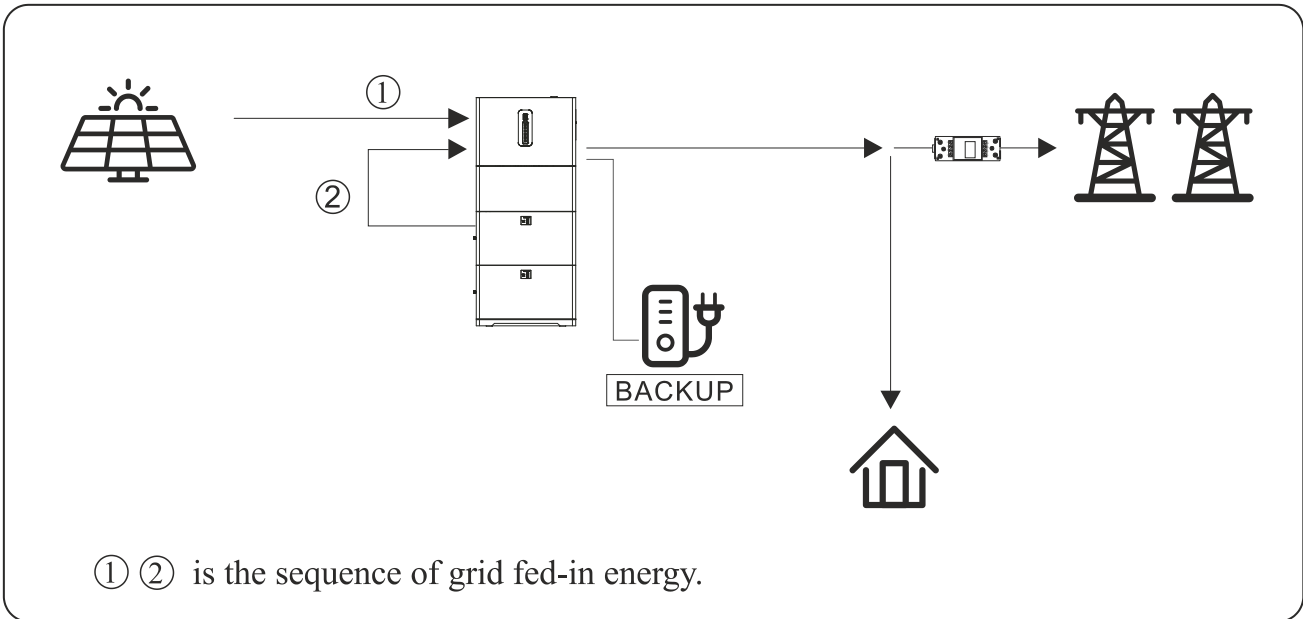

c. No PV input

When there is no PV input, the inverter will first discharge the battery energy for powering the loads. If the demand is not met then the inverter will draw power from the grid.

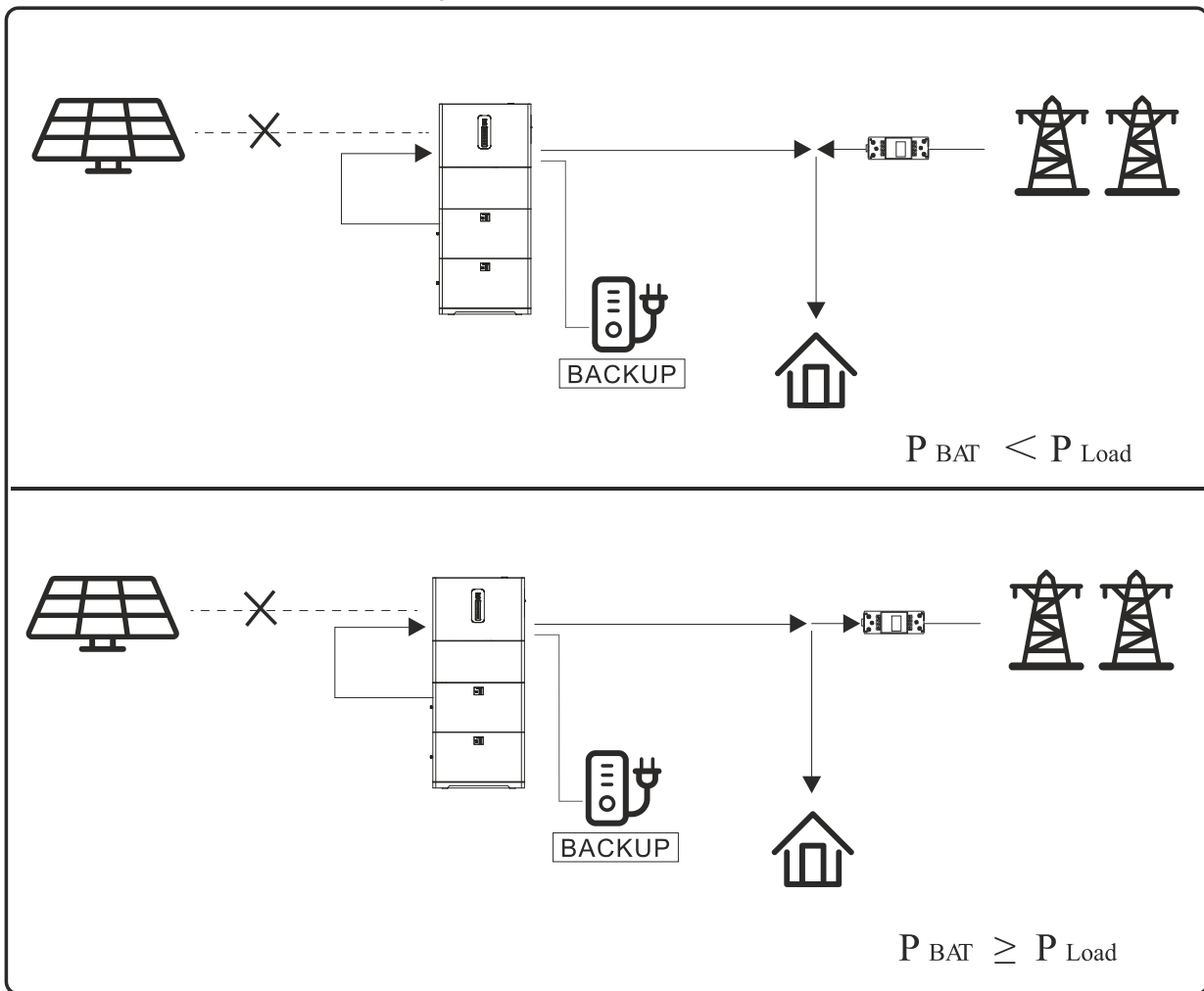

3) Time-based control mode

Under this mode, the user can control the charging and discharging of the inverter. The following parameters can be set:

- Charge and discharge frequency: one time or daily
- Charging start time: 0 to 24 hours
- Charging end time: 0 to 24 hours
- Discharge start time: 0 to 24 hours
- Discharge end time: 0 to 24 hours

The inverter can also be set to charge the battery using the grid, which is prohibited by default. If the user enables the “Grid charge function”, the “Maximum grid charger power” and “Capacity of grid charger end” can also be set. When the battery capacity reaches the “Capacity of grid charger end” parameter, the grid will stop charging the battery.

4) Back-up mode

Under this mode the priority of PV energy will be Battery > Load > Grid. This mode aims at charging the battery quickly, so it is possible to enable the AC battery charger. The back-up mode has two working behaviours: “Forbid AC charging” and “Allow AC charging”. The behaviour depends on whether the user choose to charge the battery from grid or not.

Forbid AC charging

a) Wealthy PV power

When PV energy is wealthy, PV charges the battery first, then meets the load and if there is any excess energy it will be fed into the grid.

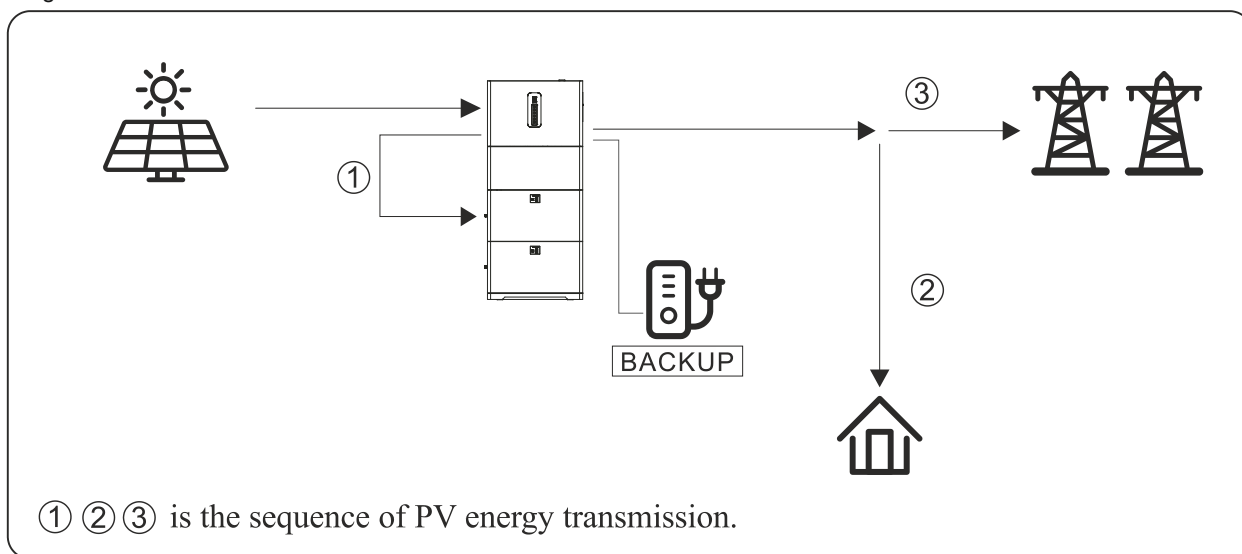

b) Limited PV power

When PV energy is limited, PV charges the battery first, the grid will be used to meet load demand.

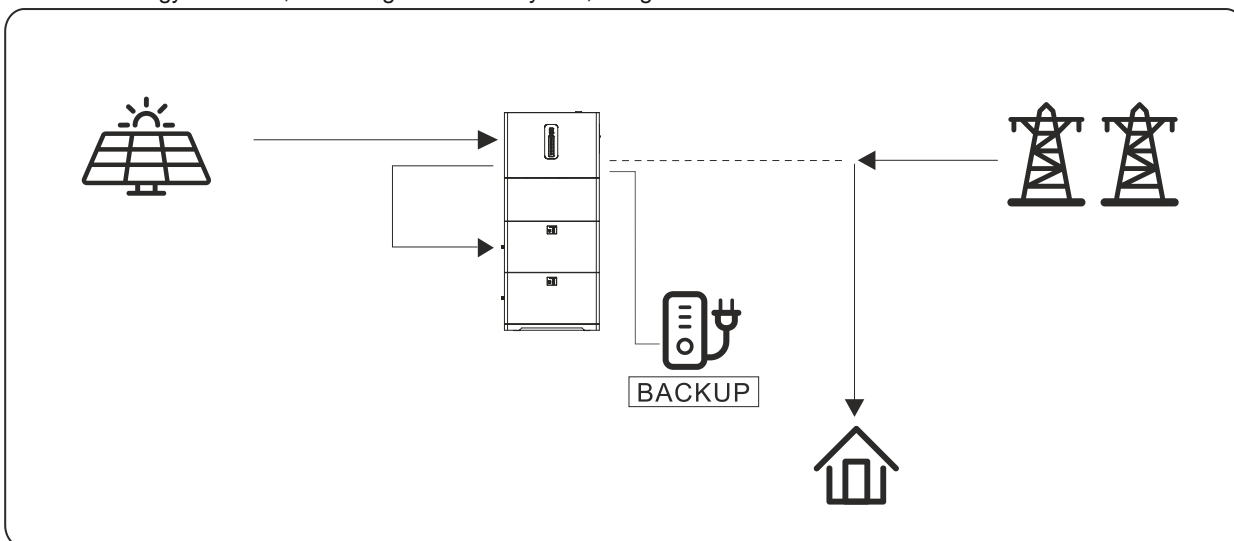

Allow AC charging

a) Wealthy PV power

When PV energy is wealthy, PV charges the battery first, then meets the load and if there is any excess energy it will be fed into the grid.

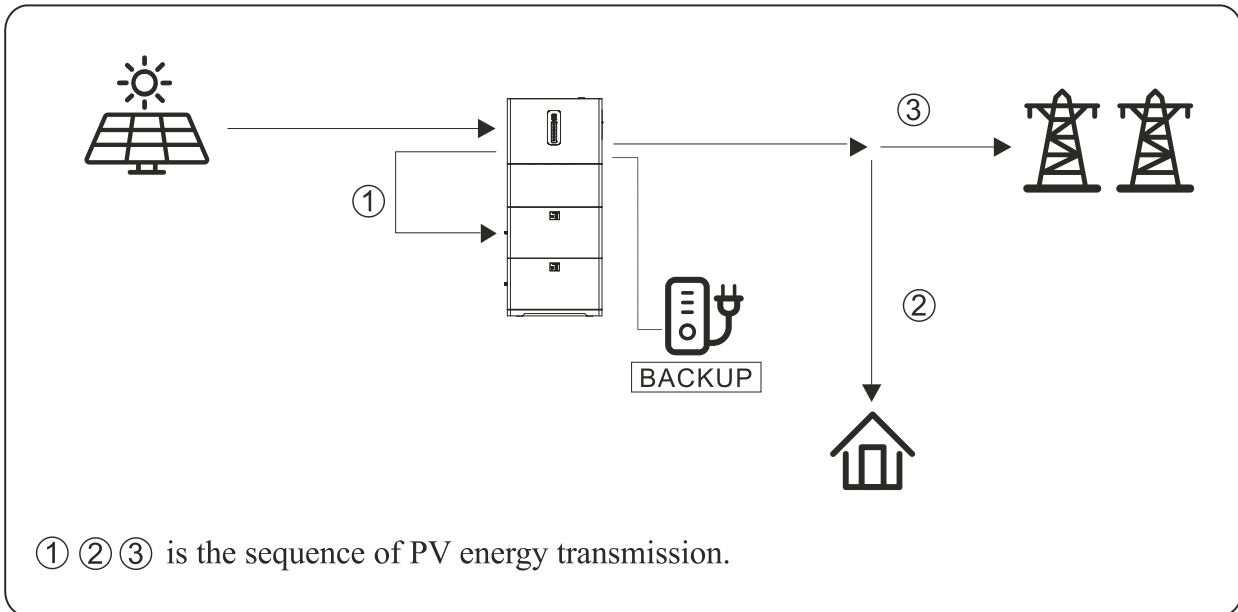

b) Limited PV power

When the PV energy is not enough to charge the battery, the grid energy will charge the battery as supplement. Meanwhile, the loads are powered from the grid energy.

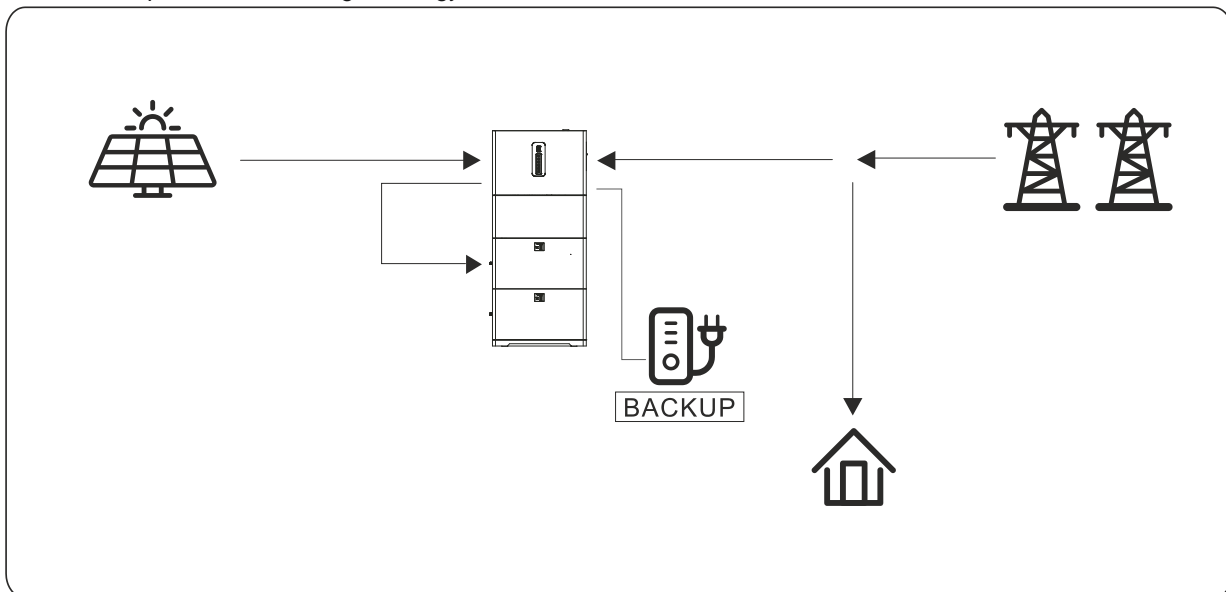

5) Off Grid mode

Under this mode only critical loads are supplied to ensure that important loads continue to work without power failure. Under this mode, the inverter can't work without the battery. This mode is automatically enabled when the inverter detects an AC grid malfunction and the EPS output is enabled in the App.

a) Wealthy PV power

When PV energy is wealthy, the PV power will be used to power the critical load. If there is excess power, the battery gets charged.

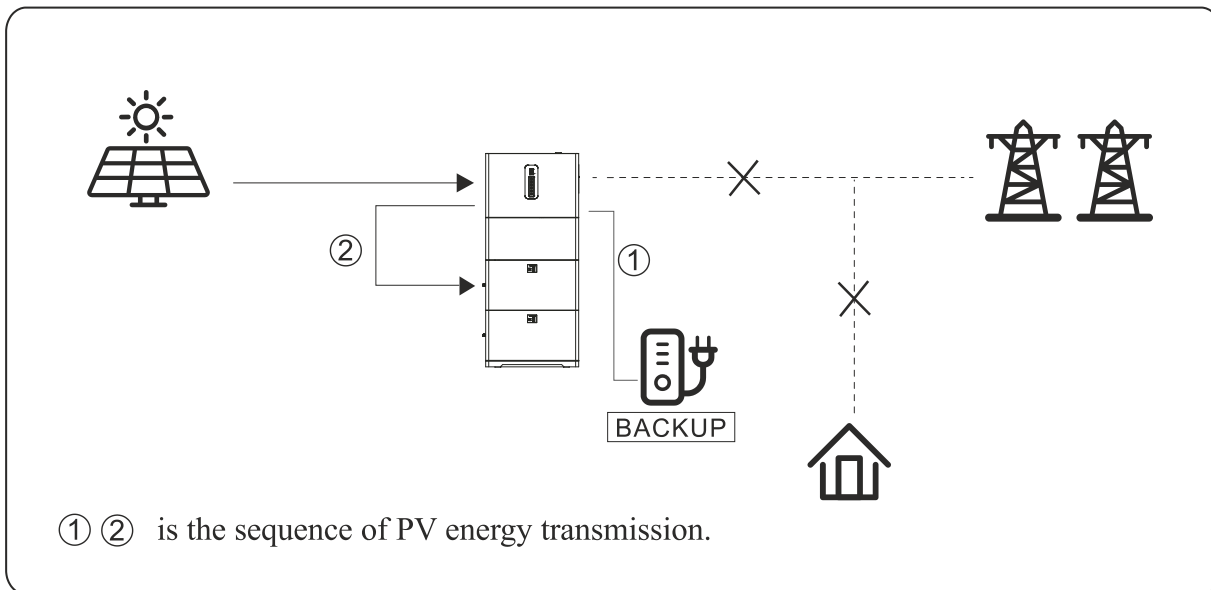

b) Limited PV power

When PV energy is limited, backup loads are powered by PV and then supplemented by the battery.

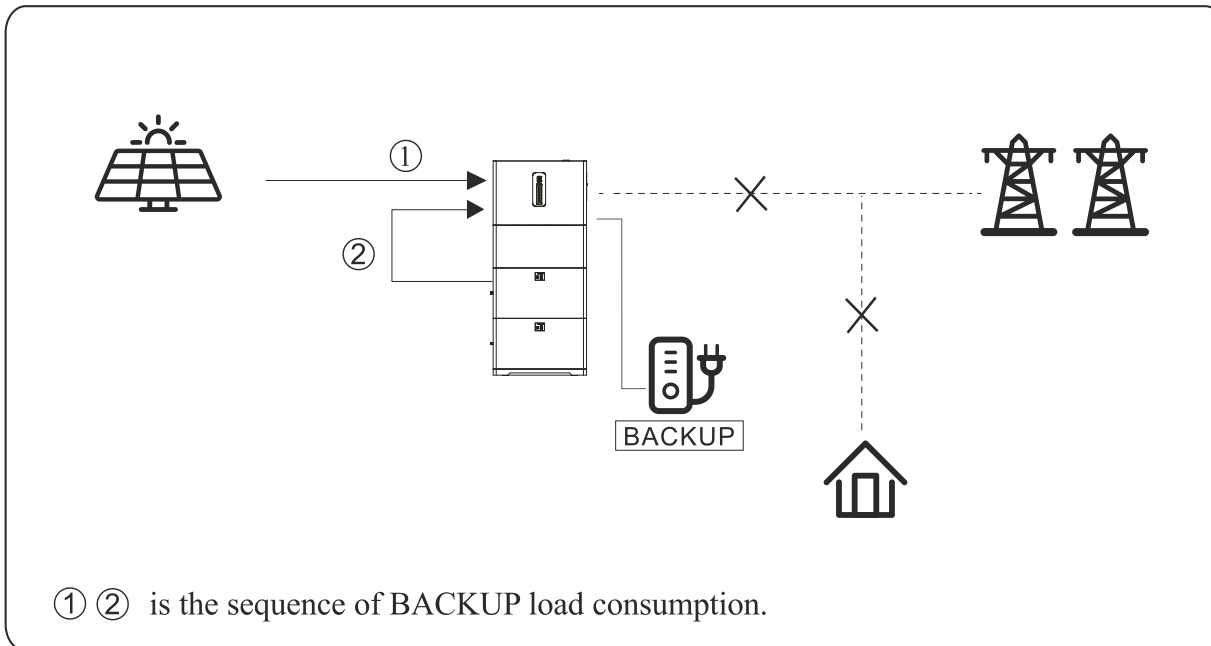

NOTICE	Before using this mode, complete the output voltage and frequency settings.
NOTICE	It is advisable to choose a battery with a capacity higher than 100Ah to ensure that this mode works normally.
NOTICE	If the loads connected to the backup output are inductive or capacitive, in order to ensure that the system remains stable and reliable, it is advisable to configure the power of these loads to be within 50% of the maximum inverter output power.

USING THE APP

Download the app

Step 1 Scan the QR code on the inverter to download the App.

Step 2 Download the App from the App Store or Google Play Store.

Step 3 Open the App. To ensure proper working of the App and the inverter, grant the access to all permissions by accepting the pop-up windows.

App Architecture

The app has a different behaviour based on the method used to connect to the inverter: it's possible to connect via "Cloud login" and "Local connection". Using the "Cloud login" method the App reads the data from the cloud server through API protocols and displays inverter parameters; using the "Local connection" method the App reads the data directly from the inverter through Bluetooth connection and display inverter parameters, it is also possible to configure various inverter parameters. The app organization is shown below.

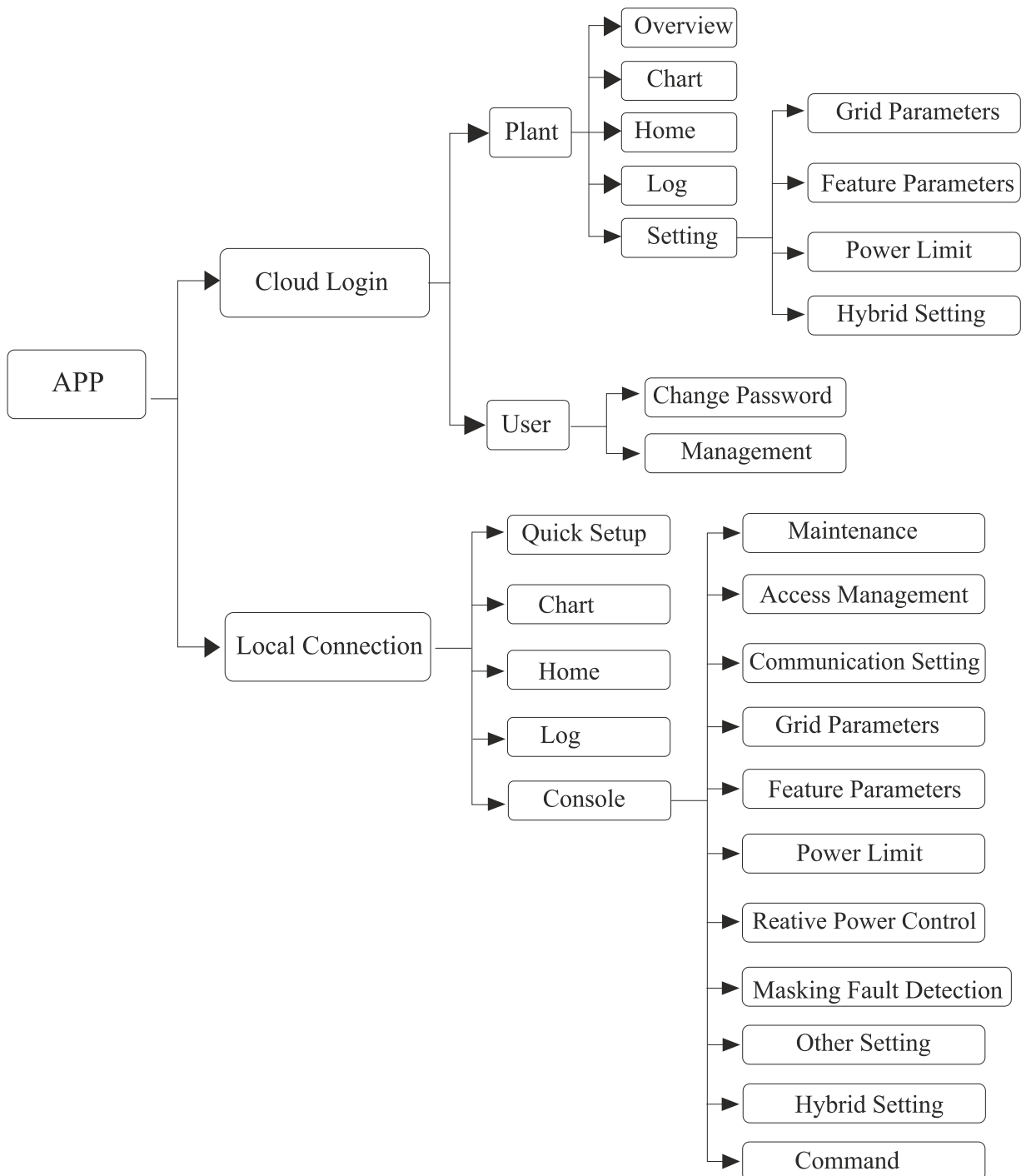

Local Setting

- **Access permission**

Before using the local setting, the App should access some permissions. You need to grant access to all permissions by clicking allow on every pop-up windows.

- **Connect inverter**

Enable Bluetooth on your device, then open the App.

Press Local Connection to go to the connect page. This page shows the inverters that have been connected and all inverters that can be connected. Press the inverter's name to connect it.

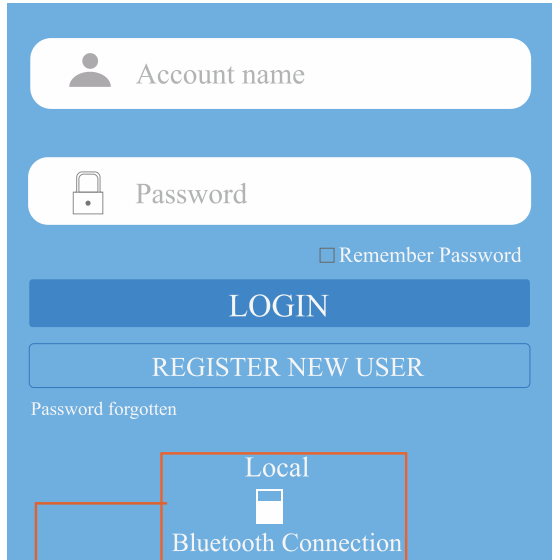

Select local connection

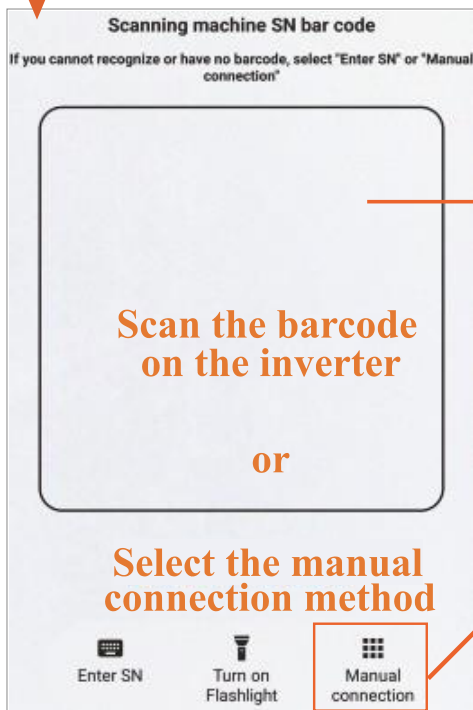

Scan the barcode on the inverter

or

Select the manual connection method

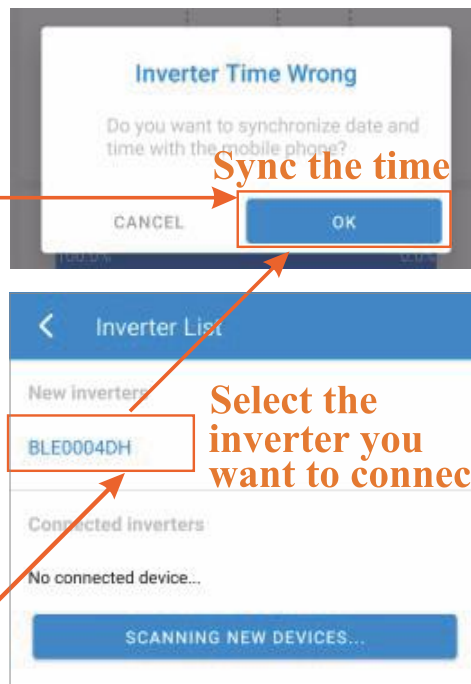

Sync the time

Select the inverter you want to connect

- **Quick setup**

1) Connect the device to the router that will be used to make the inverter connect to internet.

- Step 1** Go to Quick Settings page.
- Step 2** Ensure the Wi-Fi SSID is correct.
- Step 3** Manually insert the Wi-Fi password.
- Step 4** Click “start the configuration”.
- Step 5** When the app shows a success popup, click [Next](#).

The image shows two screenshots from an application. The left screenshot is the main dashboard, displaying energy production and consumption data. The right screenshot is a configuration step titled 'Step1 Set parameters the inverter to connect to the router'. It shows a success message 'The inverter is connected to the router' and fields for 'WIFI SSID' and 'WIFI PASSWORD'. A blue button labeled 'START THE CONFIGURATION' is visible. An orange arrow points from the 'Quick Setup' icon in the dashboard to the configuration step. Handwritten orange text provides instructions: '1) Select the wi fiSSID', '2) Insert the password', '3) Start the configuration', and '4) when success, proceed'. A 'Next' button is also visible in the configuration step.

2) Set the parameters needed for inverter operation, in this case Standard Code, Nominal voltage, Nominal Frequency and Date and Time.

- Step 1** Click each item to enter the parameters requested.
- Step 2** Click [Next](#).

The image shows a screenshot of the 'Step2 Set parameters for the inverter to connect to the power grid' screen. It contains four input fields: 'Standard Code' (IT (CEI 0-21)), 'Nominal voltage(V)' (230), 'Nominal frequency(Hz)' (50), and 'Date and Time' (2022-12-15 18:57:52). Handwritten orange text provides instructions: '1) Enter each information' and '2) Click next'. A 'Next' button is visible at the bottom right.

NOTE

The setting “Standard Code” is required for inverter operation, if it isn't set the inverter doesn't connect to the grid and it will not generate power, even if there is sufficient solar irradiation.

- 3) Set parameters for grid power, in this case the Power control method, Meter location, Power flow direction and maximum feed in grid power.

Step 1 Click each item to enter the parameters requested according to installation.

Step 2 Click [Next](#).

Step 3 If needed, press [Previous](#) to go back to the previous page.

Step3 Set parameters for the inverter to connect to the powerlimit

Power control
CT sensor

Meter location
On Grid

Power flow direction
From grid to inverter

Maximum feed in grid power(W)
6000

[Previous](#) **2) Click next** [Next](#)

- 4) Set parameters for working mode, in this case Hybrid work mode, Battery type, EPS output and maximum charger power.

Step 1 Click each item to enter the parameters requested according to user's needs and preferences.

Step 2 Click [Next](#).

Step 3 If needed, press [Previous](#) to go back to the previous page.

Step4 Set parameters for the inverter to connect to the workmode

Hybrid work mode
Self used mode

Battery type selection
RS BATLIO 5120 Lithium-ion

EPS Output

Maximum charger power(W)
1800

[Previous](#) **2) Click next** [Next](#)

- 5) Start the inverter.

Step 1 Click .

Step 2 If needed, press [Previous](#) to go back to the previous page.

XXXXXXXX

1 2 3 4 5

Step5 Please click the button below to start the inverter.

[Previous](#) **Start the inverter**

- **Chart**

Under this menu, the user can check the relevant data curve of energy (Daily, Monthly and Annual).

The App can retain informations for a limited period of time, based on the type of visualization:

- Daily Data: 7 days
- Monthly Data: 36 months
- Yearly Data: 10 years

1) **Daily data**

Go to [Chart](#) > [Day](#). The App will show the Daily production or consumption curve in this page. To choose whether to show production or consumption, the user can swipe the screen left and right to switch the graph.

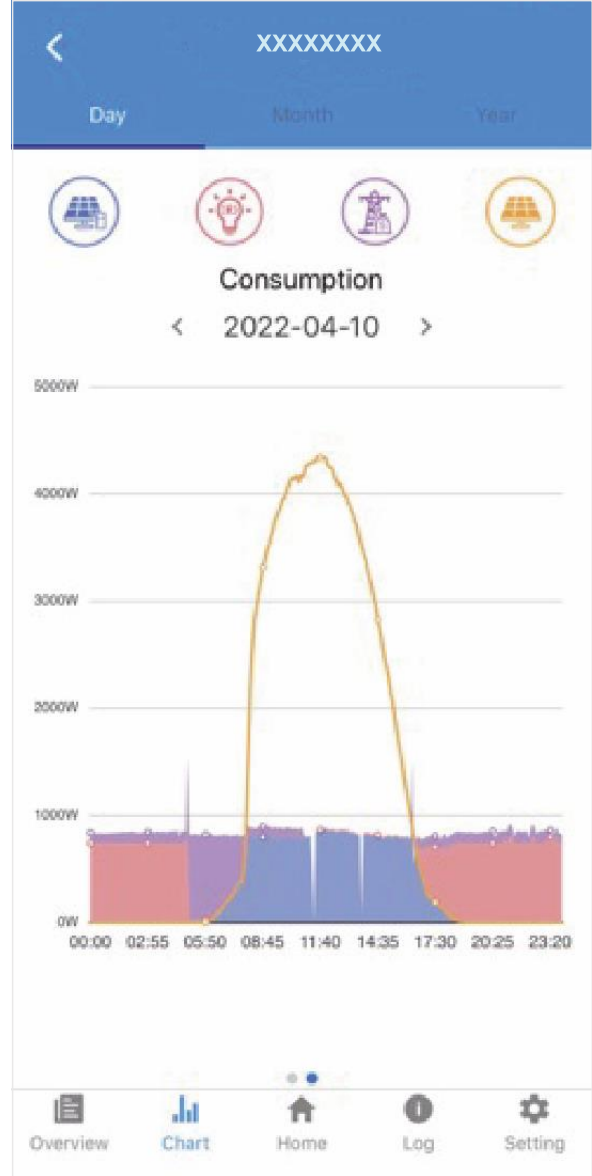
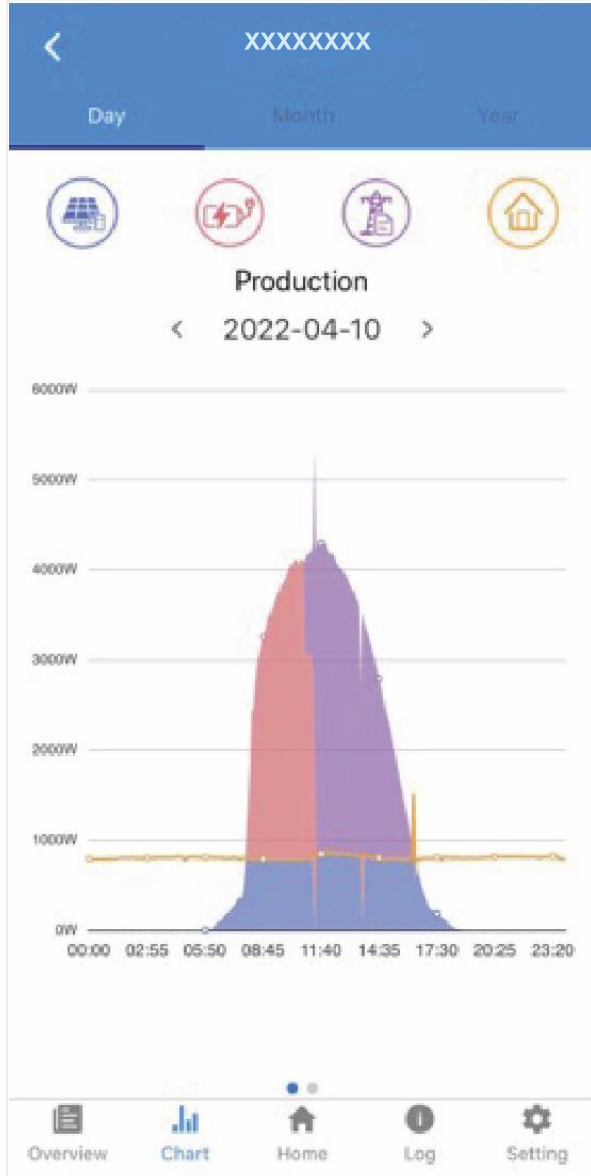

Different colour curves represent different energy data. Click the icon to show and hide the corresponding curve. Click the curves to display a small pop-up showing precise data information. The user can also press the date to choose the day to check, or as an alternative click the left and right arrows near to the date to change the day one by one.

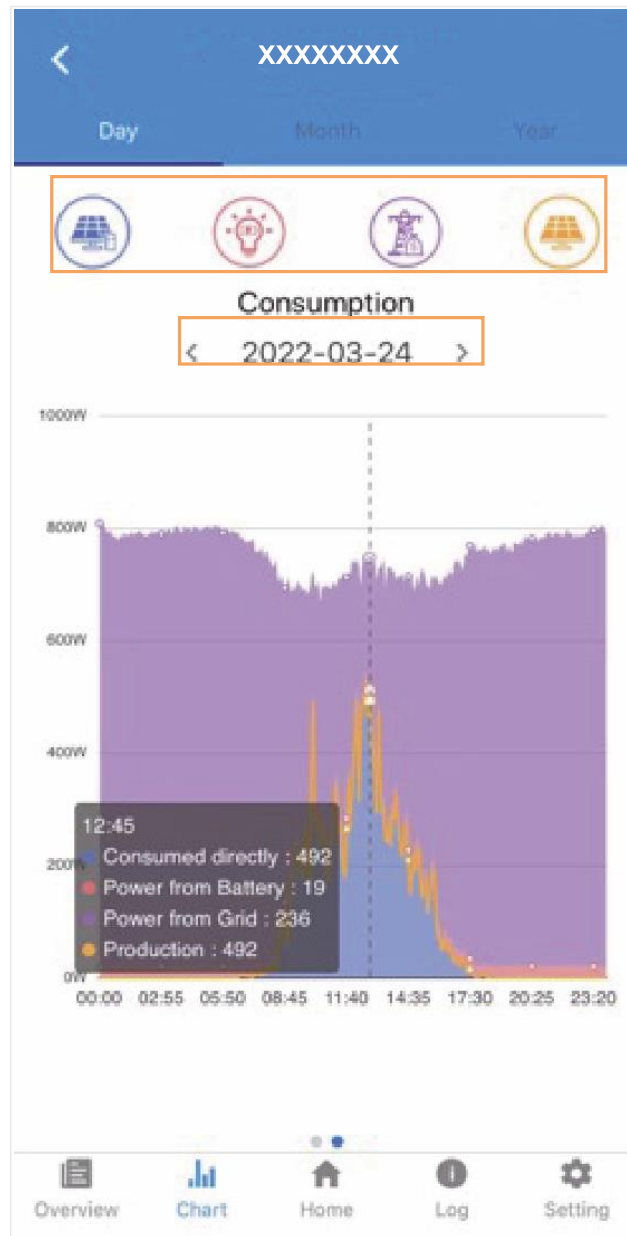

2) Monthly or yearly data

Go to [Chart](#) > [Month](#) or [Year](#) page. The App will show the Monthly or Yearly Production or Consumption bars in this page. To choose whether to show production or consumption, the user can swipe the screen left and right to switch the graph. The App behaviour are the same as the daily view.

- **Local Connection Homepage**

The Homepage shows basic information about the inverter and alarms, if any. Click  to display all active warnings and alarms; if the alarm has been taken care of, the user can also mark the alarm itself as "Inactive".

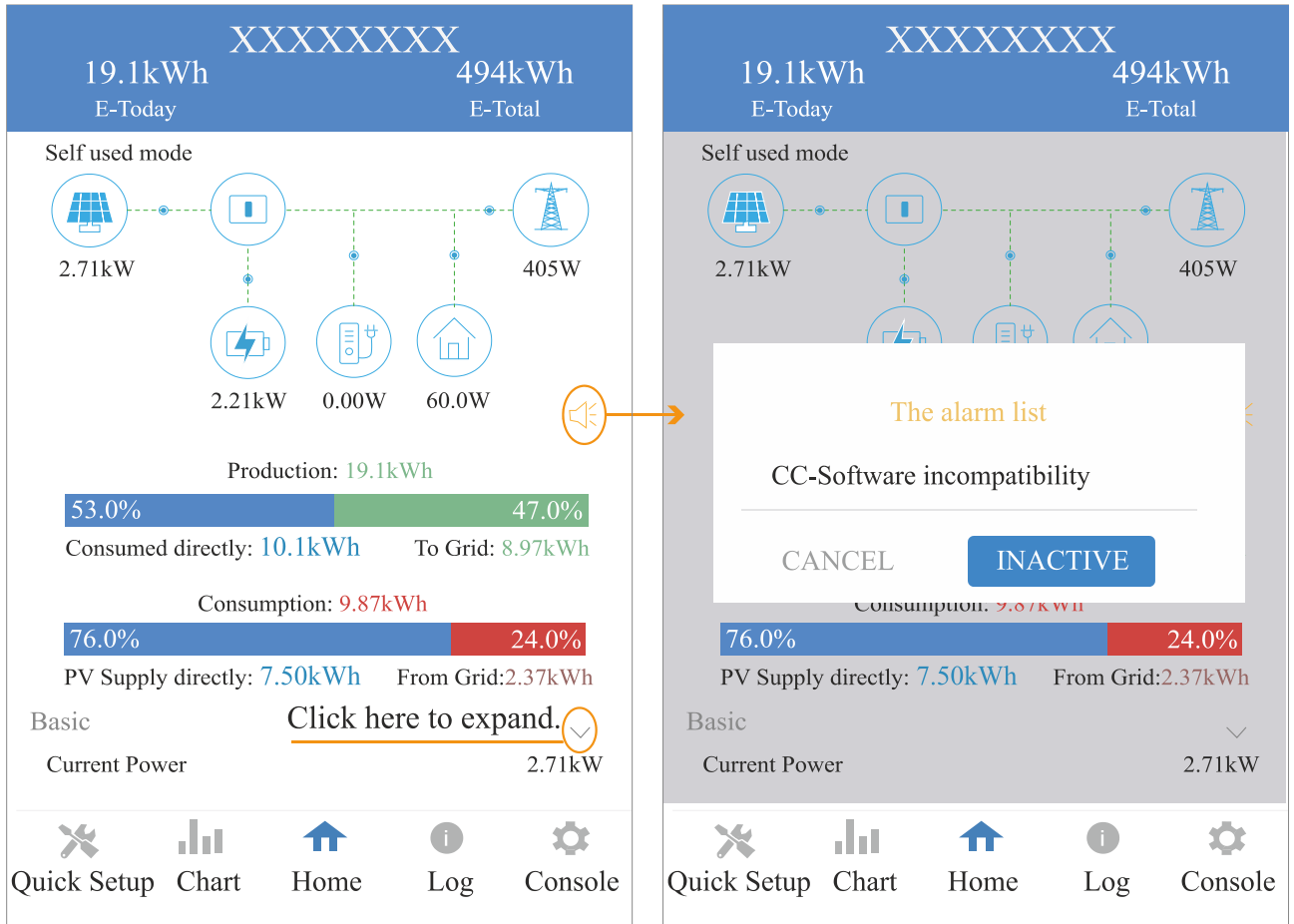

- **History Log**

Press **Log** at the bottom: it will open the History page where all the logs for the inverter can be viewed.

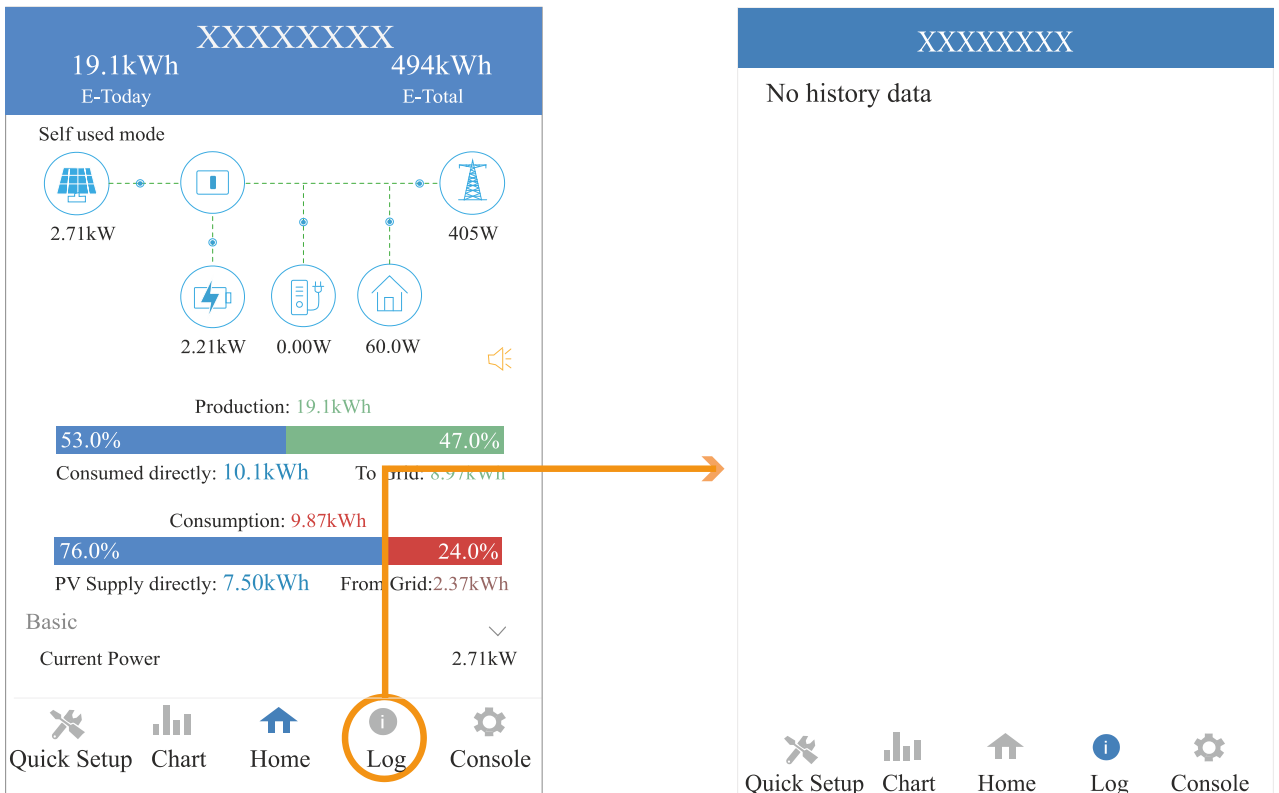

- **Console**
Access Management

Go to [Console](#) > [Access Management](#) page. In this page the user can change the login credentials and permissions.

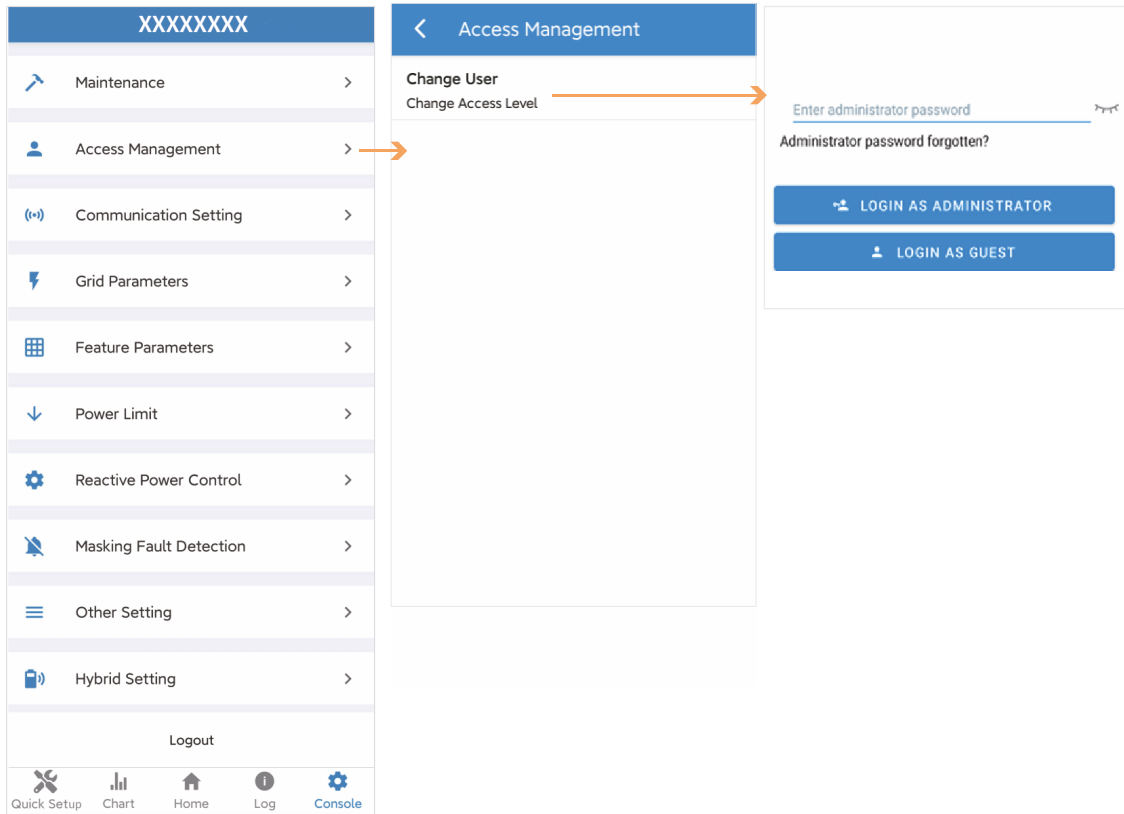

- **Communication Setting**

Go to [Console](#) > [Communication Setting](#) page. In this page the user can set or change the parameters of communication settings and it is divided in three subpages: Basic Setting, RS485 Setting and Ethernet Setting.

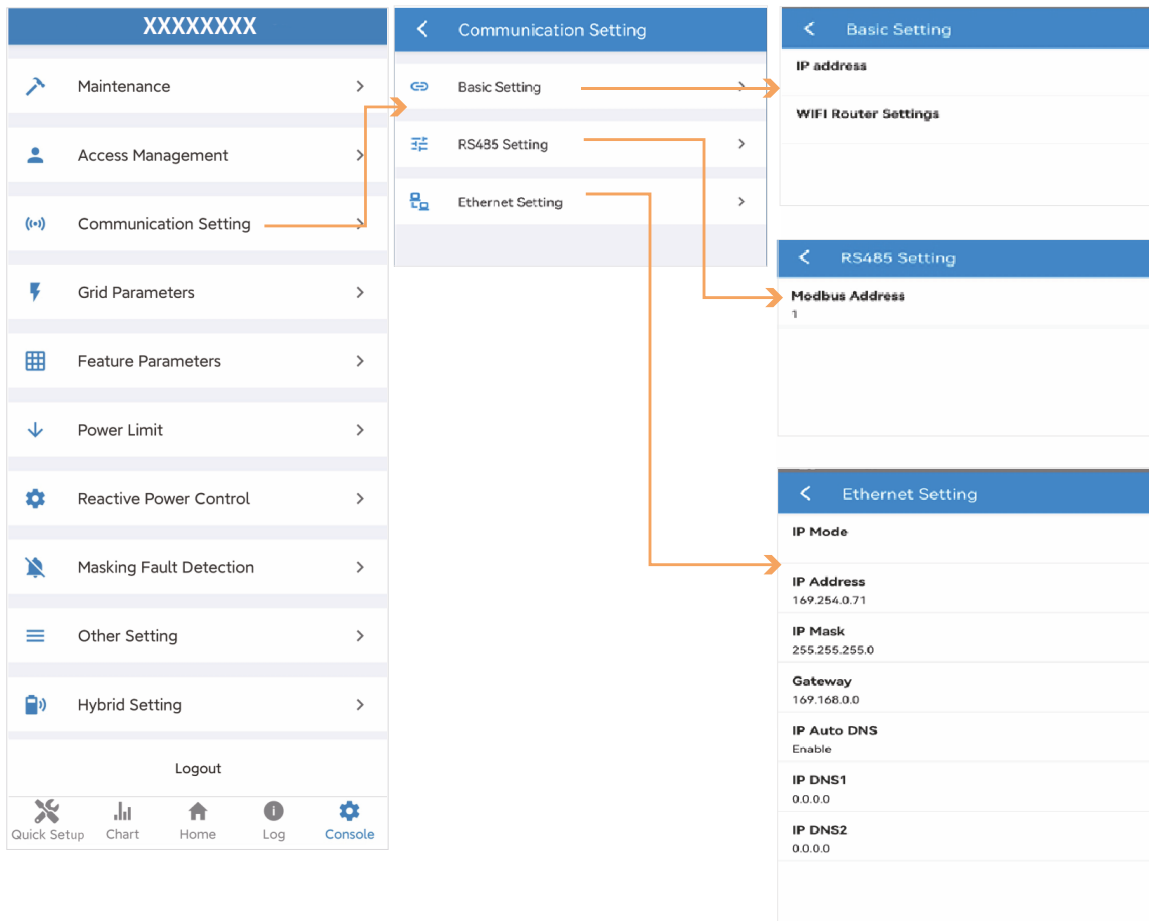

Autotest

Go to [Console](#) > [Autotest](#) page. This menu allows for easily starting the Autotest process by simply pressing on [Start](#) button.

After that Autotest is executed is possible download the result pressing the dedicated [DOWNLOAD](#) button in the bottom of the page*. A file called Autotest(date).csv will be saved in the root of the mobile phone.

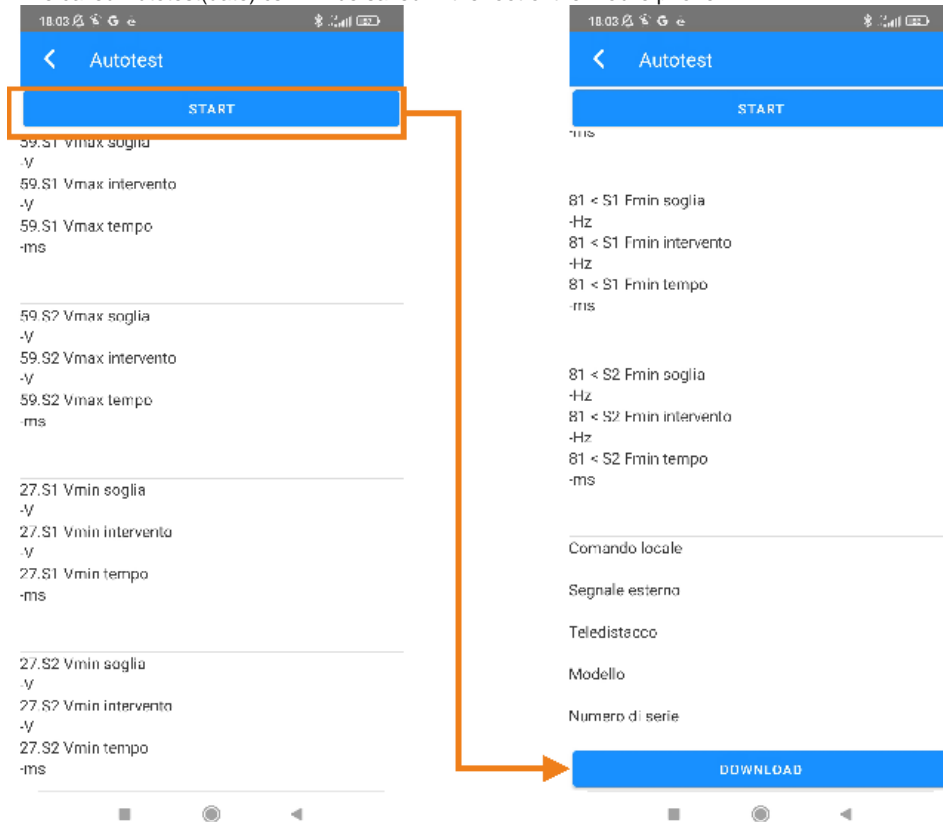

*NOTE: this function, at the moment, is available only for Android devices

Power Limit

Go to [Console](#) > [Power Limit](#) page. In this page the user can set or change the parameters of power limit.

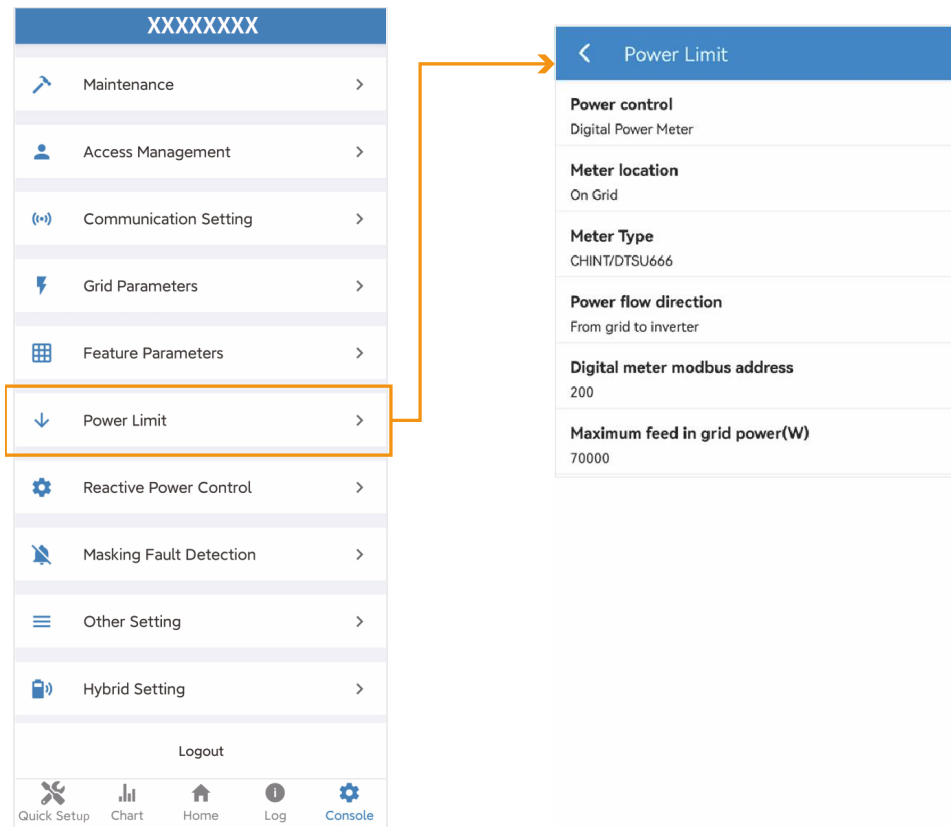

Other settings

Go to [Console](#) > [Other setting](#) page. In this page, the user can synchronize the date and time of the inverter with the device.

MAINTENANCE



WARNING

Before commissioning or performing maintenance on the inverter and its peripheral distribution unit, switch off all the charged terminals of the inverter and wait at least 5 minutes after the inverter is powered off.

Routine maintenance

Check item	Check content	Maintain content	Maintenance interval
Inverter output status	Statistically maintain the electrical yield status and remotely monitor its abnormal status.	N/A	Weekly
PV inverter cleaning	Periodically check that the heat sink is free from dust and clogging.	Clean the heatsink periodically.	Yearly
PV inverter running status	Check that the inverter is not damaged or deformed. Check for normal sound emissions during inverter operation. Check and ensure that all inverter communications are running well.	If there is any abnormal situation, contact the customer service centre.	Monthly
PV inverter electrical connections	Check that the AC, DC and communication cables are securely connected; check that the PGND cables are securely connected; check that the cables are intact and have no signs of ageing.	If there is any abnormal situation, replace the cable or re-connect it.	Half-yearly

TROUBLESHOOTING

The following table shows inverter's basic common warning and fault handling methods.

Alarm code	Alarm name	Alarm explanation	Measures recommended
A0	Grid over voltage	The grid voltage exceeds the allowed range.	<ol style="list-style-type: none"> 1) If the alarm occurs occasionally, it means that the grid is operating abnormally; the inverter can automatically restore its normal operating status after the grid returns normal. 2) If the alarm occurs repeatedly and it can automatically recover, contact the local power company to obtain permission to modify the inverter grid protection parameters with the app. 3) If the alarm occurs repeatedly for a long time, check whether: <ol style="list-style-type: none"> a. The AC circuit breaker does not open frequently (the instantaneous high pressure). b. The system has been installed according to manual: in case of inappropriate cabling, the cable impedance will cause the power grid to rise. c. The three-phase machine measures whether the voltage between the zero line and the ground line exceeds 30V which is more than the wiring of the grid. <p>If no problem can be detected, contact the customer service centre.</p>
A1	Grid under voltage	The grid voltage exceeds the allowed range.	<ol style="list-style-type: none"> 1) If the alarm occurs occasionally, it means that the grid is operating abnormally; the inverter can automatically restore its normal operating status after the grid returns normal. 2) If the alarm occurs repeatedly and it can automatically recover, contact the local power company to obtain permission to modify the inverter grid protection parameters with the app. 3) If the alarm occurs repeatedly for a long time, check whether: <ol style="list-style-type: none"> a. The AC circuit breaker is not open. b. The AC circuit breaker is not damaged (the input voltage should be consistent with the output voltage). c. The AC terminals are in good contact. <p>If no problem can be detected, contact the customer service centre.</p>
A2	Grid absent	The grid voltage is absent.	<ol style="list-style-type: none"> 1) If the alarm occurs occasionally, it means that the grid is operating abnormally; the inverter can automatically restore its normal operating status after the grid returns normal. 2) If the alarm occurs repeatedly and it can automatically recover, contact the local power company to obtain permission to modify the inverter grid protection parameters with the app. 3) If the alarm occurs repeatedly for a long time, check whether: <ol style="list-style-type: none"> a. The AC circuit breaker is not open. b. The AC circuit breaker is not damaged (the input voltage should be consistent with the output voltage). c. The AC terminals are in good contact. d. The power supply line failure. <p>If no problem can be detected, contact the customer service centre.</p>
A3	Grid over frequency	The grid frequency exceeds the allowed range.	<ol style="list-style-type: none"> 1) If the alarm occurs occasionally, it means that the grid is operating abnormally; the inverter can automatically restore its normal operating status after the grid returns normal. 2) If the alarm occurs repeatedly and it can automatically recover, contact the local power company to obtain permission to modify the inverter grid protection parameters with the app. <p>If no problem can be detected, contact the customer service centre.</p>
A4	Grid under frequency	The grid frequency exceeds the allowed range.	<ol style="list-style-type: none"> 1) If the alarm occurs occasionally, it means that the grid is operating abnormally; the inverter can automatically restore its normal operating status after the grid returns normal. 2) If the alarm occurs repeatedly and it can automatically recover, contact the local power company to obtain permission to modify the inverter grid protection parameters with the app. <p>If no problem can be detected, contact the customer service centre.</p>

Alarm code	Alarm name	Alarm explanation	Measures recommended
B0	PV over voltage	The PV module input voltage is higher than the allowed range.	1) Ensure that the maximum voltage of every single string does not exceed the maximum MPPT voltage. If this is not the case, change the PV string configuration.
B1	PV insulation abnormal	The insulation resistance against the ground is low before inverter start-up.	1) If the alarm occurs occasionally and the inverter keeps generating power, it can be caused by an external circuit. The inverter can automatically recover its normal operating status once the fault is solved. 2) If the alarm occurs repeatedly and the inverter cannot generate power reliably, check whether: a. The string output cable is connected correctly. b. Any of the PV string cable is damaged. Connect one string at the time to find the problematic string, then replace the damaged connection. If no problem can be detected, contact the customer service centre.
B2	Leakage current abnormal	The insulation resistance against the ground at the input side has decreased during inverter operation.	1) If the alarm occurs occasionally and the inverter keeps generating power, it can be caused by an external circuit. The inverter can automatically recover its normal operating status once the fault is solved. 2) If the alarm occurs repeatedly and the inverter cannot generate power reliably, check whether: a. The string output cable is connected correctly. b. Any of the PV string cable is damaged. Connect one string at the time to find the problematic string, then replace the damaged connection. If no problem can be detected, contact the customer service centre.
B4	PV under voltage	The PV module input voltage is lower than the allowed range.	1) If the alarm occurs at some specific situations (low sunlight, bad weather and/or dust storms) the string voltage is lower than normal. No action is needed. 2) If the alarm occurs with good irradiation, check whether the string lines are short-circuited, open-circuited or damaged.
B7	PV string reverse	The cables of a PV string are connected reversely.	1) Remove all strings and connect them once at the time to find the problematic one. Modify the wrong cable.
C0	Internal power supply abnormal	Inverter internal power source abnormal.	1) If the alarm occurs occasionally, the inverter can automatically recover. No action is needed. 2) If the alarm occurs repeatedly, contact the customer service centre.
C2	Inverter over dc-bias current	The DC component current in the grid exceeds the allowed range.	1) If the alarm occurs occasionally, the inverter can automatically recover. No action is needed. 2) If the alarm occurs repeatedly, contact the customer service centre.
C3	Inverter relay abnormal	The output relay cannot be closed.	1) If the alarm occurs occasionally, this could be a grid anomaly. The inverter can automatically recover. No action is needed. 2) If the alarm occurs repeatedly, ensure that the voltage between live and ground/earth are as expected. If no problem can be detected, contact the customer service centre.
C5	Inverter over temperature	Inverter internal temperature high.	1) If the alarm occurs occasionally, the inverter can automatically recover. No action is needed. 2) If the alarm occurs repeatedly, check whether: a. The inverter is not under direct sunlight. b. The heat sink is not blocked. c. All fans are working. d. Environment temperature is under 45° C 3) If no problem can be detected, contact the customer service centre.
C6	GFCI abnormal	Residual current test failed during inverter start-up.	1) If the alarm occurs occasionally and the inverter keeps generating power, it can be caused by an external circuit. The inverter can automatically recover its normal operating status once the fault is solved. 2) If the alarm occurs repeatedly or for a long period of time, contact the customer service centre.
C7	System type error		1) If this alarm occurs, the inverter cannot operate safely. Try to restart the inverter following the procedure contained in this manual. If restarting the inverter doesn't work, contact the customer service centre.

Alarm code	Alarm name	Alarm explanation	Measures recommended
C9	Unbalance DC-link voltage		<ol style="list-style-type: none"> 1) If the alarm occurs occasionally, the inverter can automatically recover. No action is needed. 2) If the alarm occurs repeatedly, contact the customer service centre.
CA	DC-link over voltage		<ol style="list-style-type: none"> 1) If the alarm occurs occasionally, the inverter can automatically recover. No action is needed. 2) If the alarm occurs repeatedly, contact the customer service centre.
CB	Internal communication error		<ol style="list-style-type: none"> 1) If the alarm occurs occasionally, the inverter can automatically recover. No action is needed. 2) If the alarm occurs repeatedly, contact the customer service centre.
CC	Software incompatibility		<ol style="list-style-type: none"> 1) If the alarm occurs occasionally, the inverter can automatically recover. No action is needed. 2) If the alarm occurs repeatedly, contact the customer service centre.
CD	Internal storage error		<ol style="list-style-type: none"> 1) If the alarm occurs occasionally, the inverter can automatically recover. No action is needed. 2) If the alarm occurs repeatedly, contact the customer service centre.
CE	Data inconsistency		<ol style="list-style-type: none"> 1) If the alarm occurs occasionally, the inverter can automatically recover. No action is needed. 2) If the alarm occurs repeatedly, contact the customer service centre.
CF	Inverter abnormal		<ol style="list-style-type: none"> 1) If the alarm occurs occasionally, the inverter can automatically recover. No action is needed. 2) If the alarm occurs repeatedly, contact the customer service centre.
CG	Boost abnormal		<ol style="list-style-type: none"> 1) If the alarm occurs occasionally, the inverter can automatically recover. No action is needed. 2) If the alarm occurs repeatedly, contact the customer service centre.
CJ	Meter lost	The communication between the inverter and the energy meter is not working.	<ol style="list-style-type: none"> 1) Check the meter parameter Settings. 2) Check if the data reported by the inverter is consistent with the data reported by the meter. 3) Ensure that the communication line between the inverter and meter is ok. 4) Ensure that the energy meter is working. <p>If no problem can be detected, contact the customer service centre.</p>
D2	Battery over voltage	The voltage at the DC battery input exceeds the allowable range.	<ol style="list-style-type: none"> 1) If the alarm occurs occasionally, the inverter can automatically recover. No action is needed. 2) If the alarm occurs repeatedly, check the battery overvoltage protection value setting in the app. Also ensure that the battery is not malfunctioning. <p>If no problem can be detected, contact the customer service centre.</p>
D3	Battery under voltage	The voltage at the DC battery input exceeds the allowable range.	<ol style="list-style-type: none"> 1) If the alarm occurs occasionally, the inverter can automatically recover. No action is needed. 2) If the alarm occurs repeatedly, check whether: <ol style="list-style-type: none"> a. The communication line between BMS and inverter is OK. b. The battery is not empty or the battery has a voltage under the cut-off voltage. c. The battery undervoltage protection is set correctly. d. The battery is not malfunctioning. <p>If no problem can be detected, contact the customer service centre.</p>
D4	Battery discharger over current	The battery discharge current exceeds the allowable range.	<ol style="list-style-type: none"> 1) Check whether the battery parameters are set correctly. 2) Check if the undervoltage alarm is active. 3) Check whether a single battery is overloaded, and if the discharge current exceeds the battery specifications. 4) Ensure the battery is not malfunctioning. <p>3) If no problem can be detected, contact the customer service centre.</p>
D5	Battery over temperature	The battery temperature exceeds the allowable range.	<ol style="list-style-type: none"> 1) If the alarm occurs occasionally, the inverter can automatically recover. No action is needed. 2) If the alarm occurs repeatedly, check whether: <ol style="list-style-type: none"> a. The battery is not under direct sunlight or the ambient temperature is too high. b. The battery is not malfunctioning. If it is the case, replace the battery. 5) If no problem can be detected, contact the customer service centre.

Alarm code	Alarm name	Alarm explanation	Measures recommended
D6	Battery under temperature	The battery temperature exceeds the allowable range.	<ol style="list-style-type: none"> 1) If the alarm occurs occasionally, the inverter can automatically recover. No action is needed. 2) If the alarm occurs repeatedly, check whether: <ol style="list-style-type: none"> a. The battery is not mounted exposed to extreme cold weather. b. The battery is not malfunctioning. If it is the case, replace the battery. <p>If no problem can be detected, contact the customer service centre.</p>
D7	Backup output voltage abnormal	The backup output voltage exceeds the allowable range.	<ol style="list-style-type: none"> 1) Check whether the backup voltage and frequency settings are within the specified range. 2) Check whether the backup port is overloaded. 3) Check if the backup port works as expected in case of a grid disconnection. <p>If no problem can be detected, contact the customer service centre.</p>
D8	Communication error (Inverter-BMS)	The communication between the inverter and the BMS is not working.	<ol style="list-style-type: none"> 1) Check whether the BMS communication cable is connected properly. 2) Check whether the battery is well connected to the inverter. 3) Confirm that the battery is compatible with the inverter. It is recommended to use CAN communication. 4) Check whether the communication cable is not damaged. <p>If no problem can be detected, contact the customer service centre.</p>
D9	Internal communication loss (E-M)		<ol style="list-style-type: none"> 1) If the alarm occurs occasionally, the inverter can automatically recover. No action is needed. 2) If the alarm occurs repeatedly, contact the customer service centre.
DA	Internal communication loss (M-D)		<ol style="list-style-type: none"> 1) If the alarm occurs occasionally, the inverter can automatically recover. No action is needed. 2) If the alarm occurs repeatedly, contact the customer service centre.
CU	DC-DC abnormal	The DC-DC converter at the input side of inverter is not working properly	<ol style="list-style-type: none"> 1) If the alarm occurs occasionally, the inverter can automatically recover. No action is needed. 2) If the alarm occurs repeatedly, check whether: <ol style="list-style-type: none"> a. The MC4 terminals on the PV side of inverter are securely connected. b. The voltage at the PV side of inverter is correct. c. There are no damaged cable or wrong connections to the PV side of inverter. <p>If no problem can be detected, contact the customer service centre.</p>
CP	Backup over dc-bias voltage	The output voltage of Backup port is higher than the DC link	<ol style="list-style-type: none"> 1) If the alarm occurs occasionally, the inverter can automatically recover. No action is needed. 2) If the alarm occurs repeatedly, the inverter can't work properly. Contact the customer service centre.
DB	Backup short circuit	The backup port of the inverter is short-circuited.	<ol style="list-style-type: none"> 1) Check whether the live and neutral wire of the backup port are not connected to each other. 3) If no problem can be detected, contact the customer service centre.
DC	Backup overload	The load connected to the backup port exceeds the allowable range.	<ol style="list-style-type: none"> 1) Disconnect the backup load and check whether the alarm gets cleared. If this is the case, reduce the load on the backup port. 2) If no problem can be detected, contact the customer service centre.



Removing the inverter

To remove the inverter, follow the steps below.

Step 1: Turn off the inverter (see dedicated chapter)

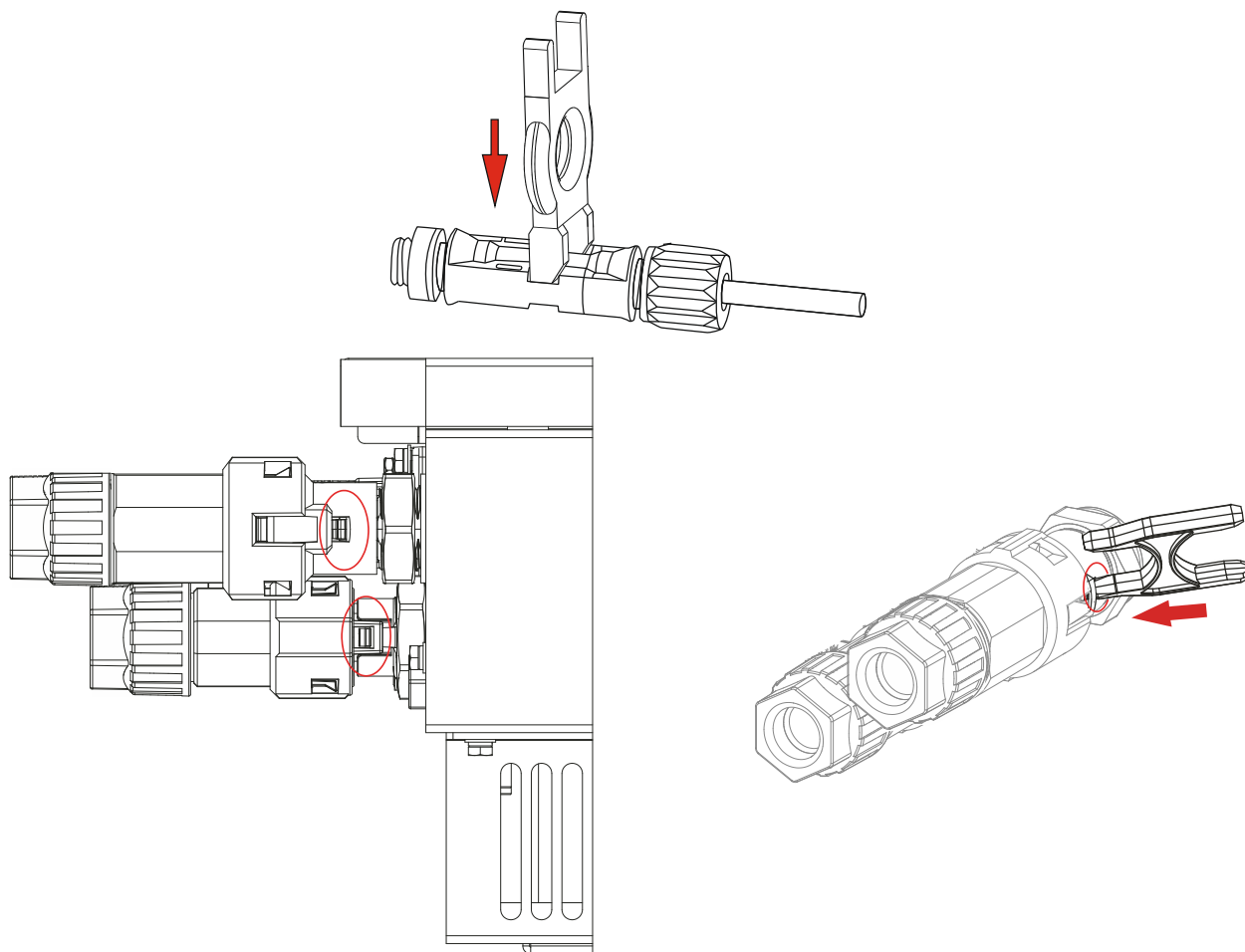
Step 2: Remove all cables from the inverter, including any communication cables, PV input, battery cables, AC output power cables and PGND cables, as shown in the following figure.



 WARNING	Before removing the PV input connector, double-check that the PV input switch is turned OFF to avoid inverter damage and personal injury.
 NOTE	When removing PV input and AC/EPS output connectors, insert the removal spanner into the bayonet, press the spanner down and take out the connector carefully.

Step 3: Unscrew the fixing screws that fasten the inverter to the rear panel.

Step 4: Remove the inverter from the rear panel.

Step 5: Remove the rear panel.

STORAGE



This chapter describes the storage requirements for the inverter.

The following storage instructions apply if the PV inverter will not be deployed immediately:

- Do not unpack the inverter (add desiccant in the original box if the PV inverter is unpacked).
- Store the PV inverter within a temperature range of -40°C to $+70^{\circ}\text{C}$ and with relative humidity between 0 and 100% (no condensing).
- The PV inverter should be stored in a clean and dry place, protected from dust and water vapour corrosion.
- A maximum of six layers of inverters can be stacked.
- Do not position the inverter tilting frontwards, tilting excessively backwards, tilting sideways or upside-down.
- Conduct periodic inspections during storage.
- Replace the packaging materials immediately if any rodent bites are found.
- Ensure that qualified personnel inspect and test the inverter before use if it has been stored for a long time.

DISPOSING OF THE PRODUCT

Users take the responsibility for the disposal of the inverter.

 WARNING	Dispose the inverter in accordance with relevant local regulations and standards to avoid property losses or casualties.
 NOTICE	Some parts of the inverter may cause environmental pollution. Please dispose of them in accordance with the disposal regulations for electronic waste applicable at the installation site.

APPENDIX

TECHNICAL SPECIFICATIONS INVERTER

Item	Specification		Comments
	RS 3.6 HYBRID	RS 6.0 HYBRID	
Model	RS 3.6 HYBRID	RS 6.0 HYBRID	
Inverter Type	Hybrid inverter		
Max. Efficiency (PV to AC)	95.7%	96.6%	
Max. Efficiency (AC to BAT)	92.3%	92.7%	
Max. Efficiency (BAT to AC)	92.6%	92.8%	
Rated Battery Voltage	51.2 Vdc		
Allowable Battery Voltage Range	40Vdc ~ 60Vdc		
PV input			
Max. PV Input Power	4500W / 4500W		
Max PV Voltage	550Vdc		
Min PV Voltage	70Vdc		
Start Operating Voltage	90Vdc		
Rated PV Voltage	360Vdc		
Number of MPP Trackers	2		
String per MPP Tracker	1		
MPPT Voltage Range	90~520Vdc		
Max input current	15A		Same for input PV1 and PV2
PV Input Short Current	20A		Same for input PV1 and PV2
AC grid output			
Rated Grid Voltage	230Vac		
Grid Voltage Range	176Vac ~ 264Vac		According to local standards
Rated Grid Frequency	50Hz / 60Hz		
Grid Frequency Range	45Hz ~ 55Hz / 55Hz ~ 65Hz		
Nominal AC Output Power	3600W	6000W	
Max. AC Output Apparent Power	3960VA	6000VA	
Max. AC Output Power (PF=1)	3600W	6000W	
Max. AC Output Current	18A	27.2A	
Power Factor	1		At rated power, adjustable to 0.8 LG – 0.8 LD)
Grid-tie Current DC Component	< 0.5% * In		
THDi	< 5%		At rated power
Backup output			
Nominal Output Voltage	230Vac		
Output Voltage Range	230Vac ± 5%		
Nominal Output Frequency	50Hz / 60Hz		
Output Frequency Range	50Hz ± 0.2% / 60Hz ± 0.2%		
Nominal Output Apparent Power	3600VA	6000VA	
Nominal Output Power	2800W	5500W	@ 51.2V battery voltage
Nominal Output Current	15.6A	26A	
Output Voltage DC Component	≤ 200mV		
Output Overload Capacity	≥ 105%		For 1s

Item	Specification		Comments
	RS 3.6 HYBRID	RS 6.0 HYBRID	
Model	RS 3.6 HYBRID	RS 6.0 HYBRID	
Transfer Time	10ms (typ), 20ms (max)		
THDv	< 3%		At rated resistive load
General			
Operating Temperature Range	-25°C ~ 60°C		Up to 40°C without derating
Storage Temperature Range	-30°C ~ 65°C		
Humidity Range	0% ~ 95%		
Max. Altitude	4000m		Up to 2000m without derating
Noise Emission	< 30 dB		
Topology	Transformerless		
Battery Input Overvoltage Category	I		
PV Input Overvoltage Category	II		
AC Output Overvoltage Category	III		
Protection Class	I		
Battery Overcurrent Protection	DC Circuit Breaker		
Degree of Protection	IP65		
Pollution Degree	PDIII acc. IEC60664-		Internal reduced to PDII
Cooling Concept	Natural		
PV Connection	MC4/H4		
Battery Connection	Dedicated DC connectors		
AC Connection	Dedicated AC connectors		For both EPS and GRID
Communication	RS485, Bluetooth, WiFi, Ethernet (optional), USB		USB is for FW upgrade only. Bluetooth is for local connection only.
Display	LEDs + App		
Grid Regulations	CEI0-21:2022 NTS Type A 2.0 (UNE 217002:2020; RD647:2020) UNE 217001: 2020/RD244:2019		
Safety Regulations	IEC/EN 62109-1: 2020 IEC/EC 62109-2: 2011 IEC 62040-1: 2017		
EMC Regulations	IEC 61000-6-1/2/4: 2019 IEC 61000-6-3: 2021		
Warranty	5 years / 10 years (optional)		
Dimensions (W * H * D)	610mm * 458mm * 232mm		
Weight	31.1kg	33.9kg	Net
	46.5kg	49.4kg	Packed

BATTERY

Item	Specification	Comments
Model	RS BATLIO 5120	
Battery Type	LFP (LiFePO4)	
Rated Battery Voltage	51.2Vdc	
Battery Voltage Range	44.8Vdc ~ 58.4Vdc	
Battery Module Energy	5.12kWh	
Max. Charge/Discharge Current	100A / 100A	
Max. No. of Module in Parallel	6	
Operating Temperature Range for Charge	0°C ~ 45°C	
Operating Temperature Range for Discharge	-20°C ~ 55°C	
Cycle Life	≥ 4000	
Dimensions (W * H * D)	610mm * 330mm * 252mm	
Weight	50.1kg	Net
	56.8kg	Packed
Overcurrent protection	DC Circuit Breaker	
Communication Protocol	CAN	
Certifications	IEC 62619:2017 EN 62619:2017 IEC 61000-6/2/4:2019 UN 38.3: Rev. 7	

SYSTEM

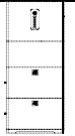
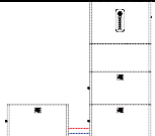
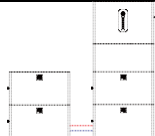
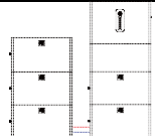
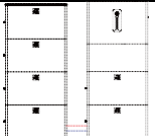
Configuration						
No. Of Batteries	1	2	3	4	5	6
Battery Total Energy	5.12kWh	10.24kWh	15.36kWh	20.48kWh	25.60kWh	30.72kWh
Usable Energy (96% DOD)	4.91kWh	10.24kWh (100% DOD)	15.36kWh (100% DOD)	20.48kWh (100% DOD)	25.60kWh (100% DOD)	30.72kWh (100% DOD)
Weight (with 3.6k inverter)	91.2kg	141.3kg	198.4kg	248.5kg	298.6kg	348.7kg
Weight (with 6.0k inverter)	94.0kg	144.1kg	201.2kg	251.3kg	301.4kg	351.5kg
Dimensions (W*H*D)	610*1072*252	610*1402*252	610*1402*252	610*1402*252	610*1402*252	610*1402*252
Dimensions (2nd tower)	N/A	N/A	610*372*252	610*702*252	610*1032*252	610*1362*252



RIELLO SOLARTECH

RPS S.p.A. - Viale Europa, 7 - 37045 Legnago (VR) Italy

divisione Riello Solartech
Via Somalia, 20 - 20032 Cormano (MI)
Tel. 800 48 48 40
e-mail: info@riello-solartech.com

www.riello-solartech.com